





PERFORMANCE EXHAUST SYSTEM

APPLICATION

MAKE	MODEL
BMW	R1200GS R1200GS Adventure
PRODUCT	
1500120220 1500120520	R77 SS Slip-On Exhaust with Carbon Fiber Sleeve; Carbon Fiber Endcap R77 SS Slip-On Exhaust with Stainless Steel Sleeve; Carbon Fiber Endcap

- 
 This product is designed for use in closed course racing and is not intended for highway use. In the state of California, it is illegal to modify the emission control system, which includes the fuel injection of any vehicle.
- 
 You must know how to remove and replace your stock exhaust in order to install this product otherwise have it installed by a professional mechanic. Keep all stock parts from your existing system as some components may be necessary to install your new Yoshimura exhaust depending on the application.
- 
 Read through all instructions before beginning installation. Exhaust system can be extremely hot. Let motorcycle cool down before beginning installation. Always wear hand and eye protection and take precautionary measures to avoid injury.

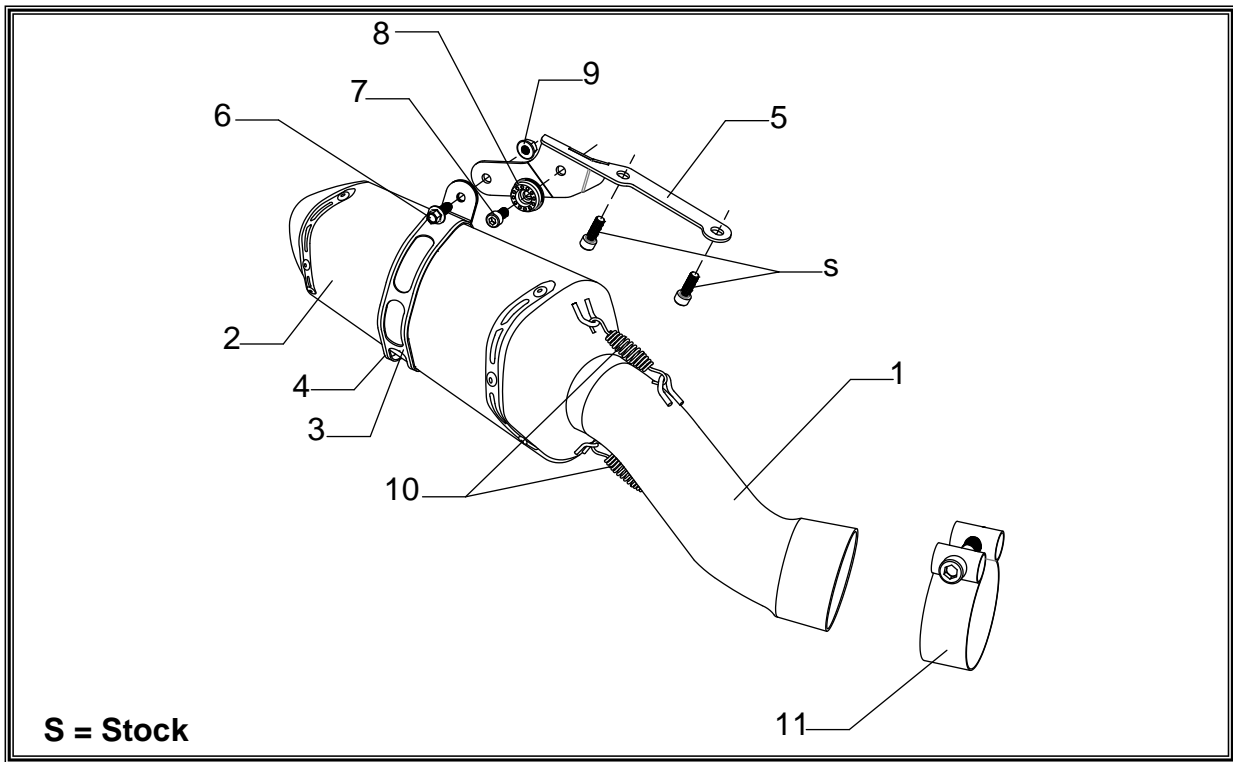

No.	Part #	Description	Qty
1	15001-435-1	Yoshimura Tailpipe	1
2	1500120220-RMA 1500120520-RMA	Yoshimura Muffler Carbon Fiber Sleeve Stainless Steel Sleeve	1
3	1121-MPCA 1121-MPCAX	Muffler Clamp Carbon Fiber Sleeve Stainless Steel Sleeve	1
4	HT SHLDR77	Muffler Clamp Heat Shield	1
5	15001-BRKT-01	Muffler Mount Bracket	1
6	M8X20H	8mm x 20mm Flanged Hex Head Bolt	1
7	M8X16	8mm x 16mm Socket Head Cap Screw	1
8	M8ALCSW-00	8mm Counter Sink Washer	1
9	8MMNUT	8mm Flange Nut	1
10	RACE-SPS-1	Medium Exhaust Spring	2
11	27-73M	Exhaust Clamp	1
**	ST-200	Spring Puller	1
**	17029	Yoshimura Sticker Sheet	1

-TOOLS REQUIRED-

Metric Socket Set • Combination Wrench Set • Torque Wrench • Torx Socket Set

-REMOVAL-

1. Removing the stock muffler.

- a) Remove the stock heat shield between the muffler and header by removing the (2) heatshield bolts.**
- b) Loosen the stock exhaust clamp between the muffler and header.**
- c) While securely supporting the stock muffler, remove muffler mount bolt and carefully remove stock muffler assembly.**
- d) Remove stock exhaust clamp as it will not be used with the Yoshimura slip-on system.**

-INSTALLATION-

1. Small parts installation.

- a) Remove the right side passenger foot peg bracket by removing the (2) bolts securing foot peg bracket to the frame.**
- b) Install (15001-BRKT-01) muffler mount bracket between frame and right side passenger foot peg bracket using the (M8X16) bolt and (M8ALCSW-00) countersink washer provided in the kit in conjunction with the stock foot peg bracket bolts. See diagram for proper orientation and order of hardware. Torque bolts to factory specification.**
Note: Due to slight variations in the factory subframe, there may be a small gap between the muffler mount bracket and the stock muffler mount. Torqueing the (M18X16) bolt to factory specification will close the gap between the muffler mount bracket and stock subframe.
- c) Slide (27-73M) exhaust clamp over Yoshimura tailpipe outlet.**
- d) Install (HT SHLDR77) muffler clamp heat shield onto (1121-MPCA/X) muffler clamp.**
Note: Some trimming of the rubber heat shield may be required.
- e) Slide muffler clamp onto muffler.**

2. Installing the Yoshimura Slip-On System.

- a) Install Yoshimura muffler/tailpipe assembly onto stock header.**
Note: Removal of the exhaust spring may be required to rotate the muffler and tailpipe independently to achieve desired alignment. Re-install exhaust springs.
- b) Bolt muffler clamp to muffler mount bracket using the (M8X20H) bolt and (8MMNUT) nut provided in the kit.**
- c) Torque muffler mount bolt to 12lb-ft. (1.6kg-m, 16Nm)**
- d) Torque exhaust clamp to 12lb-ft. (1.6kg-m, 16Nm)**

3. Fitment check and Notes.

- a) Before starting motorcycle, check for proper clearance between new exhaust system and rear suspension (i.e. tire, swing-arm, brake, rear shock, engine, and etc.) If any problem is found, please carefully follow through the installation steps again. If problem still persists, please call Yoshimura Tech Department at (800) 634-9166 / in CA (909) 628-4722.**
- b) It is recommended that the muffler and tailpipe be wiped down with rubbing alcohol to remove oil and fingerprints. This will help prevent tarnishing of the finish after the exhaust is heated up.**
- c) Note: After starting motorcycle, it is normal for new exhaust system and muffler to emit smoke until oil residue burns off.**