

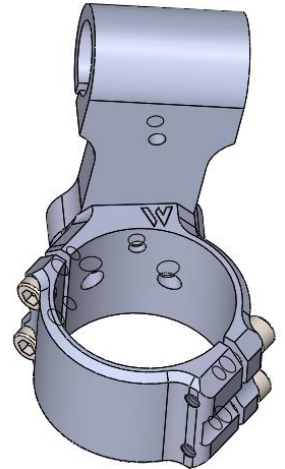

Clipon Riser (med / high) Installation Instructions

WARNING Installation and use of some Woodcraft Technologies, Inc. products will change the response of the motorcycle to rider control inputs. Failure of the rider to adapt to these changes may cause loss of control, and serious injury or death. Improper installation, and/or failure to comply with all warnings and instructions may cause loss of control and serious injury or death. **DO NOT INSTALL OR USE ANY WOODCRAFT TECHNOLOGIES, INC. PRODUCTS IF YOU ARE UNABLE TO DO SO IN COMPLIANCE WITH ALL INSTRUCTIONS AND WARNINGS. SEEK THE ASSISTANCE OF AN EXPERIENCED TECHNICIAN.**

- 1) Completely remove your stock grips, controls and clipon assembly.
- 2) Most OEM controls have anti rotation pins, which require you to drill holes in the Woodcraft handlebars. Measure the diameter of the holes in the stock handlebars and select the appropriate drill bit.
- 3) Slide the controls loosely into place, noting that the grips should end roughly where the plastic end plug meets the aluminum. Mark the location for the anti rotation pins and drill. Test the control assemblies to be sure that they are able to be securely tightened and that everything moves freely.
- 4) Install the four 6x20mm socket cap clamping bolts on each clipon and secure the main clipon body on the fork tube, finger tight.



The right clipon will have the “W” on the right side of the clamp.

- 5) Install the riser. **VERY IMPORTANT:** Use loctite on all three of the countersunk bolts on each side when securing the riser to the base of the clipon. Allow the loctite to dry and fully set before use.
- 6) Install the handlebars and controls into. Set the pullback to a comfortable position and then snug them in place. Rotate the handlebars lock to lock and ensure there is adequate clearance.

NOTE: These are not model specific clipons. You must check very carefully for adequate clearance and that the throttle snaps shut for all parts throughout the entire range of steering. Also, you must fully extend the forks and be sure that the brake lines do not get pulled tight.

Read the warning below carefully.

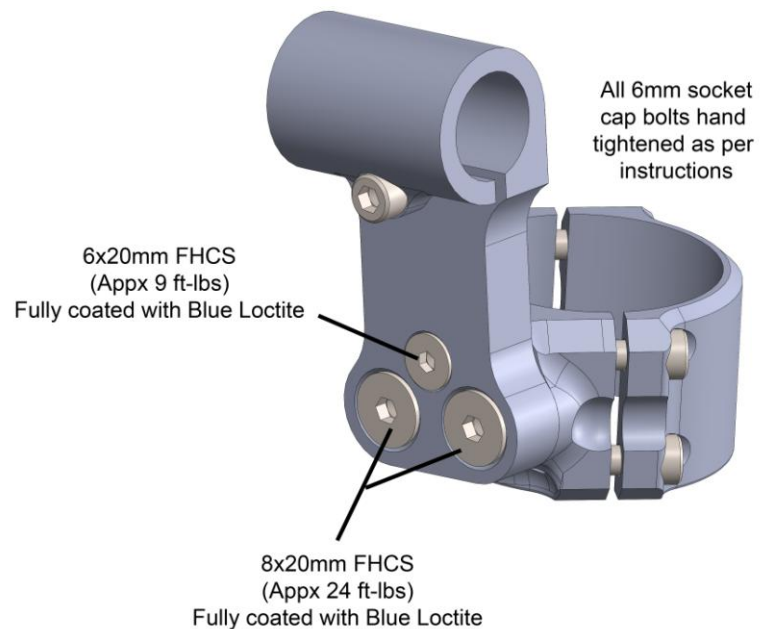

WARNING - VERY IMPORTANT : Ensure that the cables, hoses and all control parts do not contact any part of the motorcycle and that you have full ability to manipulate the controls throughout the entire range of steering. Also, be sure that the throttle returns freely after being fully opened throughout the entire range of steering. **FAILURE TO HEED THESE WARNINGS MAY CAUSE LOSS OF CONTROL OF MOTORCYCLE AND SERIOUS INJURY OR DEATH. DO NOT OPERATE THE MOTORCYCLE IF THERE ARE ANY INTERFERENCE ISSUES WITH EITHER THE MOTORCYCLE PARTS OR YOUR BODY, OR WITH A THROTTLE THAT DOES NOT RETURN FREELY.**

- 7) Once you have set the position of the handlebars, fully tighten the pinch bolt for the bars with a hand 90-degree allen wrench.
- 8) Before fully tightening the four mounting bolts, you should finger tighten the bolts so that the gap between the two halves of the clipon base is even on both sides. Next, snug all four bolts by hand with a 90 degree allen wrench. Next, fully tighten* the two forward bolts. Then, fully tighten the two rear bolts. Perform a final check on all four bolts, ensuring that they are all equally and fully tight.

IMPORTANT : After tightening all fasteners according to instructions and to industry-standard* torque specs, attempt to force each unit to slip on fork tube. **ANY ABILITY OF A CLIP-ON TO SLIP CAN CAUSE LOSS OF CONTROL AND SERIOUS INJURY OR DEATH. NEVER OPERATE MOTORCYCLE WITH A SLIPPING CLIP-ON.**