

WOODCRAFT CFMOTORSPORTS

105 Baldwinville Rd. Winchendon, MA 01475
(978)297-2977

BMW S1000RR Race Only Rearset Instruction Sheet : 05-0752

Thank you for selecting CFMOTORSPORTS rearsets. The components you have just purchased for your motorcycle are designed to improve the ground clearance, crash worthiness and overall good looks of your motorcycle. Please note that these components are intended and approved for **racing use only**. As such, the footpegs are solid-mount and provisions for brake light switches are not provided with the kit.

- 1) Remove stock rearsets, footpegs and associated hardware. All components that are re-used in this kit should be cleaned and inspected for damage before re-installation.

IMPORTANT

Tighten all fasteners to factory specification or industry standard. FAILURE TO PROPERLY TIGHTEN ALL FASTENERS MAY CAUSE DAMAGE TO THE MOTORCYCLE, LOSS OF CONTROL AND SERIOUS INJURY OR DEATH.

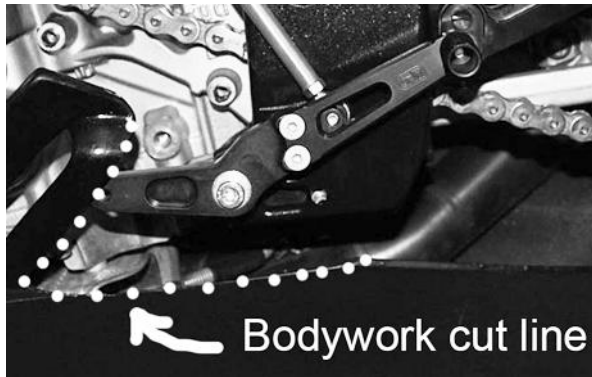
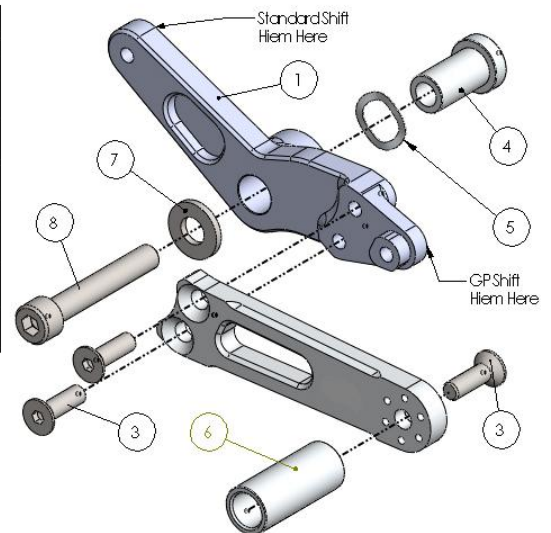

Figure 1

IMPORTANT NOTE: This kit requires trimming the bodywork to enable the use of our special shifter. The cut lines for the bodywork are shown as dotted lines in the photo in Figure 1.

ITEM NO.	PART NUMBER	DESCRIPTION	QTY.
1	08-0752P	Shift Pivot	1
2	09-4145	2 Hole Shaft	1
3	04-FH620Z	6x20mm FHCS	3
4	08-0752SP	Shift Pivot Pin	1
5	04-WA531	Wave Washer	1
6	08-4899	Toe Peg	1
7	04-WABZ	8mm flat washer	1
8	04-SC850Z	8x50mm SHCS	1



Shift Side Assembly Installation

- 1) See the diagram at the right - Assemble the CFM pedal shaft to the shift pivot and bolt the pedal tip to the shaft. **IMPORTANT:** secure these bolts with **BLUE LOCTITE**.
- 2) In order to secure the shift pedal to the frame you need to take the 6mm bodywork mount on the frame and drill and tap 8mm threads in this location. **NOTE:** You must tap the threads deep (at least 25mm deep).
- 3) Secure the BMW quickshifter and hiem joint directly to the back side of the shift pivot in the appropriate location. Use the diagram to the right to determine the orientation of the shift rod and quickshifter for each shifting pattern. Secure the bolt with **BLUE LOCTITE**.
- 4) Bolt the shift pedal to the frame using the 8mm flat washer, shift pivot pin, wave washer and 8x50mm bolt. Place the wave washer between the backside of the shift pivot and the pivot pin. Be sure to apply quality waterproof grease to the surface of the pivot pin to ensure smooth lever operation. Secure the 8mm bolt with **BLUE LOCTITE**.
- 5) **Important:** Secure the wire coming off of the shifter prevent contact with the chain (zip ties). Be sure to leave enough slack so that the rod can move when shifting.
- 6) Bolt the CFM footpeg to the bracket using the included 10mm hardware. You will want to try the peg and bracket in several locations to determine where you are most comfortable. **IMPORTANT** – Once you have determined the final location, secure the footpeg bolt with **BLUE LOCTITE**. Rotate the eccentric to the desired foot position and note the hole location – be sure to put both pegs in the same location.
- 7) Bolt the shift bracket assembly to the frame using the 8x30mm bolts, placing the spacers between the bracket and the frame.

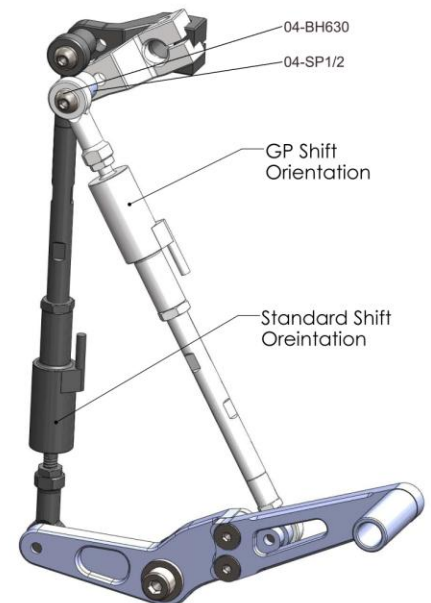

- 8) Bolt the upper heim joint to the splined shift arm on the engine. You must be sure to place the 1/2" long spacer between the heim joint and the arm. The arm should make roughly a 90 degree angle with the shift rod and should be slid so that it sits flush with the end of the splined shaft coming out of the engine.
- 9) Adjust the shift rod to bring the pedal tip to the proper height. Note: The BMW quickshifter does not have very deep threads. You may need to start the shift rod 2-3 turns on the opposite heim joint before starting into the quickshifter. Once done, lock the rod in place with the OEM locknuts (be sure they are on both sides of the rod).
- 10) Secure heel guard to the outside of the brackets with the included 6x16mm bolts using **BLUE LOCTITE**.

Brake Side Assembly Installation

- 1) Bolt the CFM footpeg to the bracket using the included 10mm hardware.
IMPORTANT - Secure bolt with **BLUE LOCTITE**.
Rotate the eccentric to the same location as the shift side.
- 2) Assemble the CFM brake pedal using a **BLUE LOCTITE** on all of the bolts. Install the brake pedal to the backside of the bracket using the OEM pedal pivot and bolt. Be sure to generously apply quality waterproof grease to the sliding surface of the pivot in order to ensure smooth lever operation. Secure the bolt with **BLUE LOCTITE**.
- 3) Bolt the master cylinder, spacers, heel guard and pedal spring return plate in place using the 6x40mm bolts and locknuts included. The spacers go between the master cylinder and the bracket. The OEM return plate goes inside the master cylinder. Attach the master cylinder clevice to the brake pedal using the OEM brake pin. The pin should be oriented so that the cotter pin and washer are on the inside. With the pedal return plate installed, you can attach the OEM return spring.
- 4) Bolt the brake bracket loosely to the frame using the supplied 8x30mm hardware, placing the included spacers between the bracket and the frame.
- 5) Install the OEM BMW rubber exhaust damper, inner spacer and outer spacer in the CFM exhaust mount. A small amount of grease can help this procedure. Install the 8x30mm main exhaust bolt and the two 6x16mm bracket mount bolts finger tight. Next, fully tighten the main bracket mounting bolts and the exhaust mount bolt. Finally, remove the 2 small exhaust bracket mounts one at a time and secure them both for final assembly with **BLUE LOCTITE**.

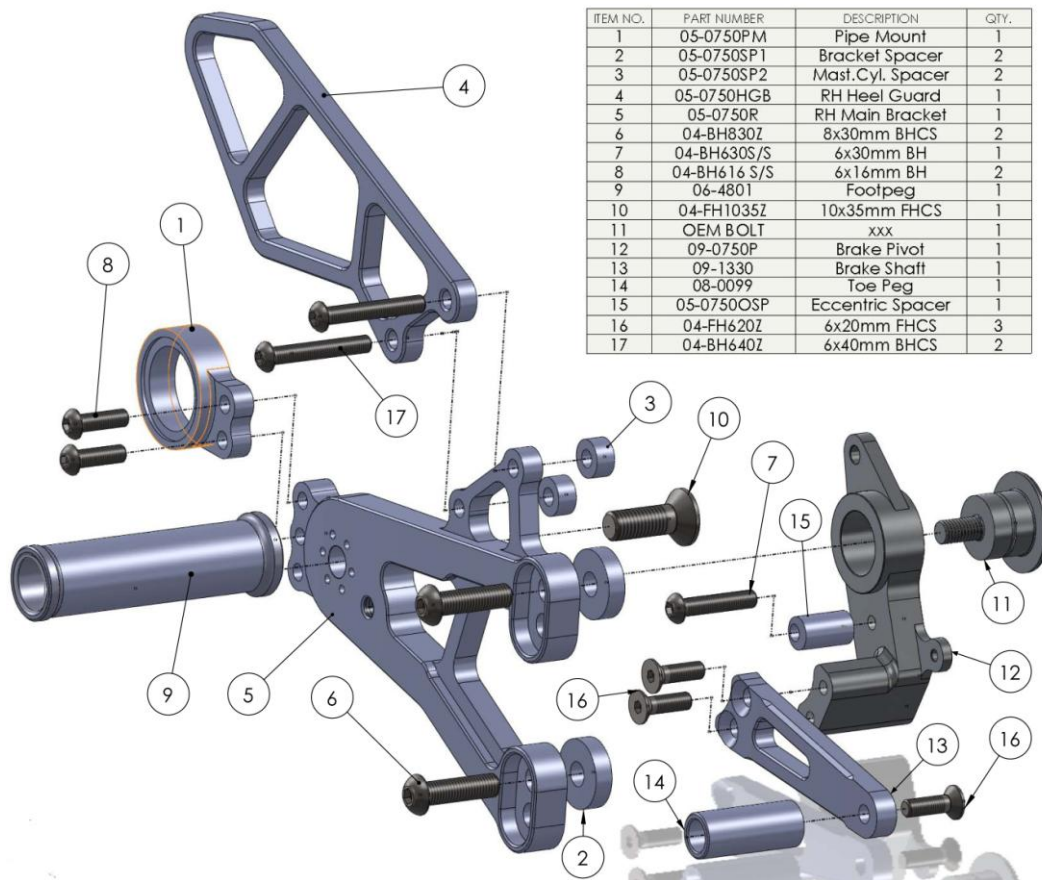

ITEM NO.	PART NUMBER	DESCRIPTION	QTY.
1	05-0750PM	Pipe Mount	1
2	05-0750SP1	Bracket Spacer	2
3	05-0750SP2	Mast. Cyl. Spacer	2
4	05-0750HGB	RH Heel Guard	1
5	05-0750R	RH Main Bracket	1
6	04-BH830Z	8x30mm BHCS	2
7	04-BH630S/S	6x30mm BH	1
8	04-BH616 S/S	6x16mm BH	2
9	06-4801	Footpeg	1
10	04-FH1035Z	10x35mm FHCS	1
11	OEM BOLT	xxx	1
12	09-0750P	Brake Pivot	1
13	09-1330	Brake Shaft	1
14	08-0099	Toe Peg	1
15	05-0750OSP	Eccentric Spacer	1
16	04-FH620Z	6x20mm FHCS	3
17	04-BH640Z	6x40mm BHCS	2

BE SURE THAT ALL COMPONENTS OPERATE AND RETURN FREELY BEFORE USE

If you have any questions regarding installation, please feel free to contact us.

IMPORTANT Installation and use of this product will change the response of the motorcycle to rider control inputs. Failure of the rider to adapt to these changes may result in a loss of control, and serious injury or death. Improper installation and/or failure to comply with all warnings and instructions may cause a loss of control and serious injury or death. **DO NOT INSTALL OR USE THIS PRODUCT IF YOU ARE UNABLE TO DO SO IN COMPLIANCE WITH ALL INSTRUCTIONS AND WARNINGS. SEEK THE ASSISTANCE OF A PROFESSIONAL TECHNICIAN.**