



Fender Eliminator Kit

APPLICATION

MAKE	MODEL
BMW	S1000RR S1000R
PRODUCT	
070BG152001	Fender Eliminator Kit

! This product is not DOT approved. Yoshimura R&D of America, Inc. is not liable or responsible for any resulting event caused by the installation of this product. Check with local laws and regulations for compliance prior to installation and use. This product is not intended for use on public highways.

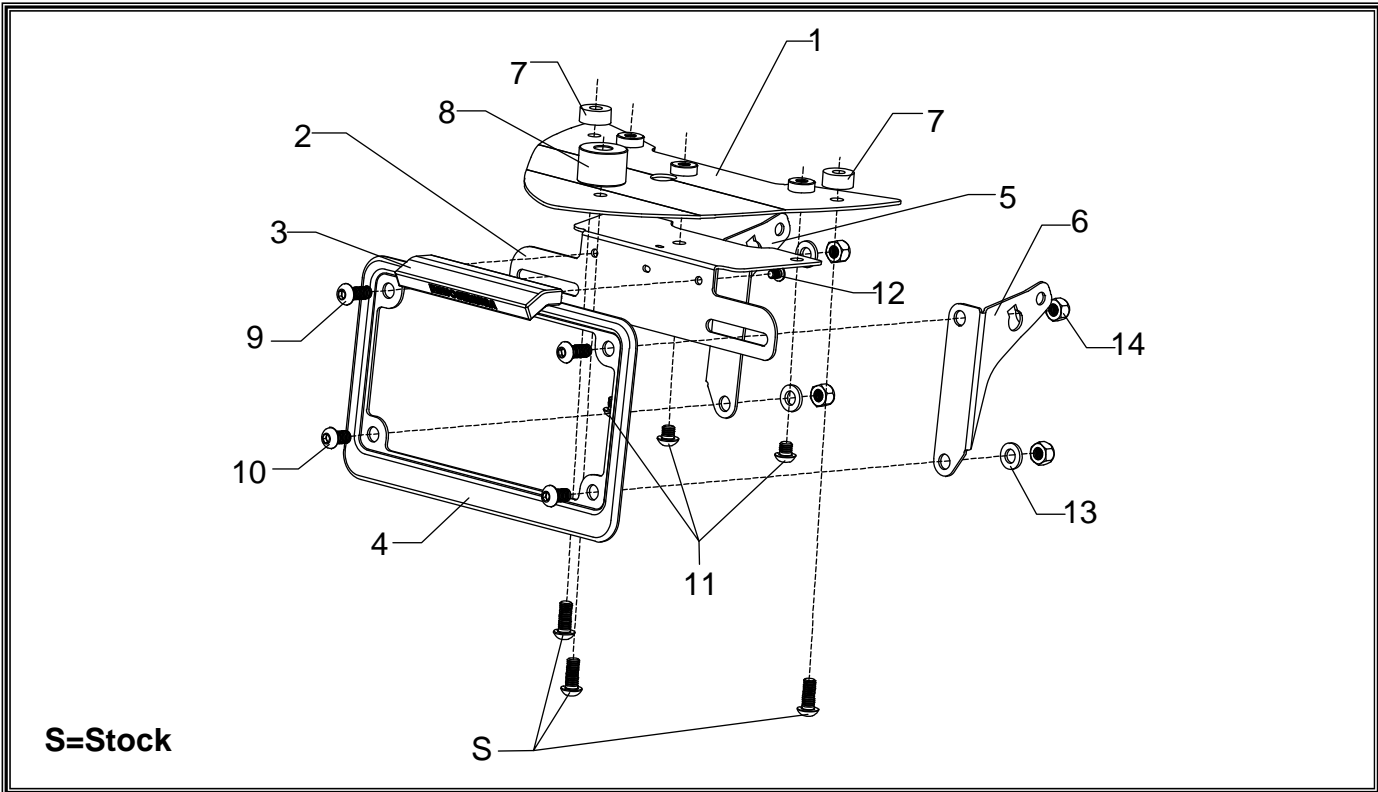

No.	Part #	Description	Qty
1	1520-FEB-01	Yoshimura Fender Eliminator	1
2	15200-FEBKT	Yoshimura Fender Eliminator Bracket	1
3	070BG-LH-K	Yoshimura LED Fender Eliminator Light	1
4	070BG-LPF	Yoshimura Aluminum License Plate Frame	1
5	15200-TSB-L	Left Turn Signal Bracket	1
6	15200-TSB-R	Right Turn Signal Bracket	1
7	6X7SPC	Aluminum Spacer	2
8	8x17SPC	Aluminum Spacer	1
9	M6X16BHS	6mm x 16mm Button Head Screw	2
10	M6X12BHS	6mm x 12mm Button Head Screw	2
11	M6X6BHS	6mm x 6mm Button Head Screw	3
12	M4X6BHS	4mm x 6mm Button Head Screw	2
13	6MMWASHER	6mm Washer	4
14	6MMLN	Nylon Lock Nut	4
**	ZT-200	Zip Ties	3
**	94785-01-ND	Butt Connectors	2
**	17029	Yoshimura Sticker Sheet	1

-TOOLS REQUIRED-

Metric Socket Set • Combination Wrench Set • Metric Allen Wrench Set • Torx Bit Set

-REMOVAL-

1. **Remove Rear Cowl or Passenger seat and disconnect rear tail light and turn signal harness plug.**
2. **Remove fender assembly by unbolting the (3) Torx bolts. Remove tail light and turn signal harness from fender assembly. Disconnect the turn signal wires from the turn signals by removing the lamp cover and disassemble stock turn signals from fender assembly.**
3. **Remove undertail cowling by unbolting the (6) Torx bolts from underneath. Then remove the (2) front spacers as indicated in Fig. 1. After removing the spacers, re-install cowl using the (6) stock Torx bolts.**



Fig. 1

-INSTALLATION-

1. **Install Yoshimura LED license plate light onto fender eliminator using the (2) provided 4mm screws.**
2. **Assemble Yoshimura Fender Eliminator Kit as shown in the parts diagram. Yoshimura fender eliminator is mounted to the stock subframe using the (3) stock Torx bolts in conjunction with the provided aluminum spacers. See diagram for proper orientation and order of hardware.**
3. **Attach Yoshimura Fender Eliminator Kit beneath rear undertail using supplied hardware as shown in the parts diagram.**
Note: Do not tighten bolts to subframe at this time.
4. **Cut off and remove 2" of the sleeve at the middle of the harness where the wires split off to each of the turn signals and to the rear license plate illumination light. Cut off the stock license plate illumination light wires 75mm away from the light.**
5. **Route license plate light and turn signal harness through stock opening in undertail cowling.**
6. **Tighten Yoshimura Fender Eliminator mounting bolts to subframe. Torque to 7ft-lbs (10N-m).**
7. **Using the supplied butt connectors, connect the license plate illumination light wires to the plate light and turn signal harness as follows:**

**Yoshimura FE Wire-----Stock Sub-harness
Red Wire-----Green Wire
Black Wire-----Brown Wire**

Note: Use of soldering and heat shrink tubing is recommended.

8. **Attach stock turn signals to Yoshimura fender assembly.**
9. **Route stock turn signal wires and connect to the stock turn signals, inserting wires through the stock turn signal mounting stalks. Note the (+) and (-) as shown in Fig. 2.**

Turn Signal Wire Description

S1000RR	S1000R
Green w/ White Stripe — Left Turn Signal (+)	Blue w/ Red Stripe — Left Turn Signal (+)
Blue w/ Black Stripe — Right Turn Signal (+)	Blue w/ Black Stripe — Right Turn Signal (+)
Brown — Ground (-)	Brown — Ground (-)

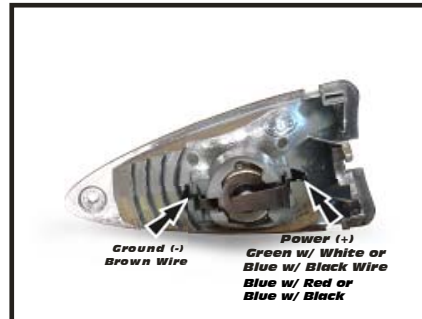

Fig. 2

10. **To prevent loose wires and/or connections, route and secure the wires inside the tail section using the provided zip ties from the kit.**
11. **Re-install cowl cover or rear seat.**
12. **Check for function of license plate light and turn signals and that all brackets and components are secure prior to riding.**