



YOSHIMURA

RESEARCH & DEVELOPMENT OF AMERICA, INC.

5420 DANIELS STREET STE A, CHINO CA. 91786 · (800)634-9166 · (909)628-4722 · FACSIMILE (909)591-2198

www.yoshimura-rd.com

RS-1/RS-3 PERFORMANCE EXHAUST

**KAWASAKI
'01-04
ZRX1200**

143055(2,5,7)

ZYCLONE BOLT ON SYSTEM

143045(2,5,7)

RACE ONLY BOLT ON SYSTEM

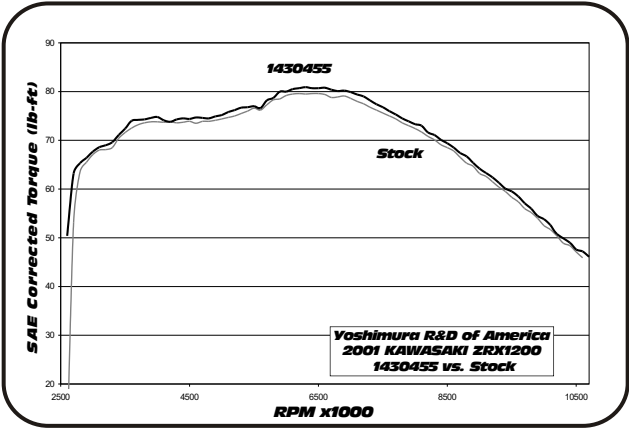
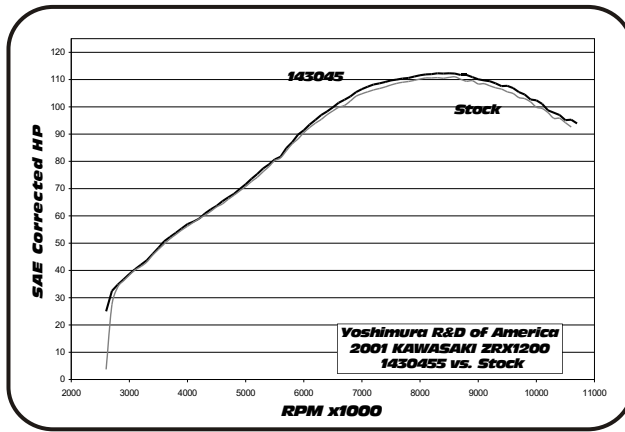

Note: Dyno graphs are for comparison use only. Actual results may vary depending on operating and motorcycle condition.



THIS PRODUCT IS DESIGNED FOR USE IN CLOSED COURSE RACING AND IS NOT INTENDED FOR HIGHWAY USE.



NOTE: IN THE STATE OF CALIFORNIA, IT IS ILLEGAL TO MODIFY THE EMISSION CONTROL SYSTEM. WHICH INCLUDES THE CARBURETORS OF ANY VEHICLE.

Caution: Exhaust system can be extremely hot. Let motorcycle cool down before beginning installation.

Note: Read through all instructions before beginning installation.

Tools Needed:

12mm and 14mm sockets
3/8" ratchet and extension
Torque wrench
5mm allen head wrench

Installation Steps:

1 Remove stock muffler by removing flange cover on stock muffler (2 allen head bolts). Remove 3 mounting nuts on muffler flange, unbolt muffler bracket, remove muffler and gasket..

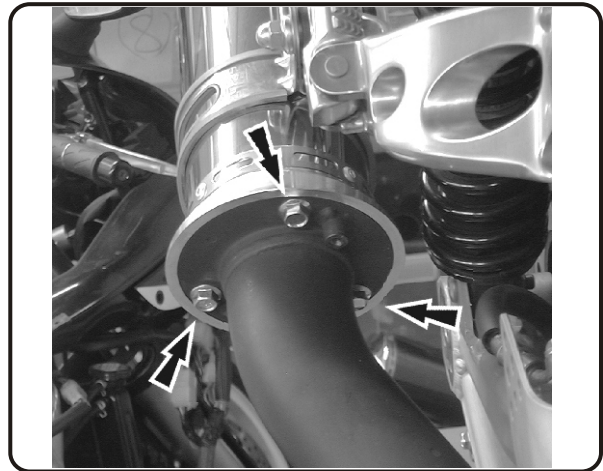

Fig. 1

2 Install new muffler gasket
(Not supplied - Kawasaki part no. 11060-1213)

3 Install Yoshimura muffler using supplied bolts.
(See Fig. 1) Torque bolts to 2.3 kg-m (16.5 lb-ft).

4 Apply heat insulator to inside of muffler clamp and slide clamp onto muffler.
(note direction of clamp in Fig. 3)

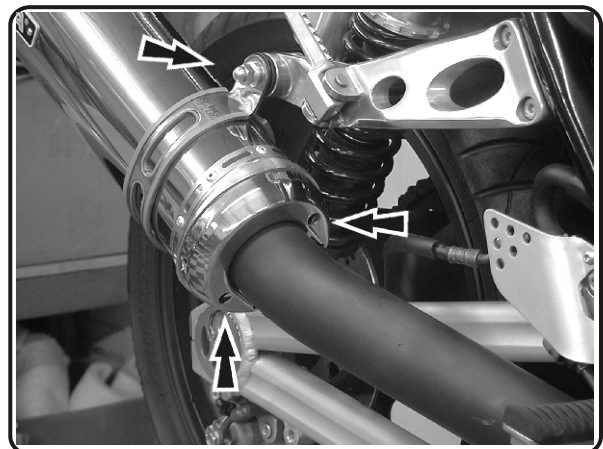

Fig. 2

5 Mount clamp to stock muffler bracket using stock bolt, washer, and nut. (Fig. 2)
Torque bolt to 2.5 kg-m (18 lb-ft)

6 Replace muffler flange cover using stock bolts.
(Fig. 2).

7 Check for proper clearance between new muffler and motorcycle. (i.e. swing-arm, passenger foot-peg, rear wheel, etc.) If any problem is found, please carefully follow through the installation steps again. If problem still persists, please call Yoshimura tech. Dept. at (800)634-9166 / in CA (909)628-4722

Note: After starting motorcycle, it is normal for new muffler to emit smoke until oil residue burns off.

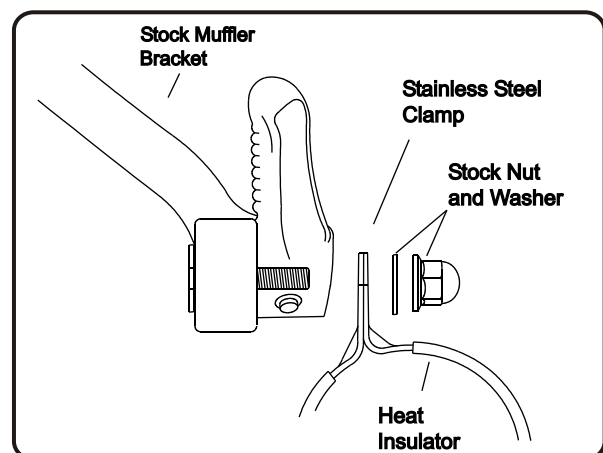
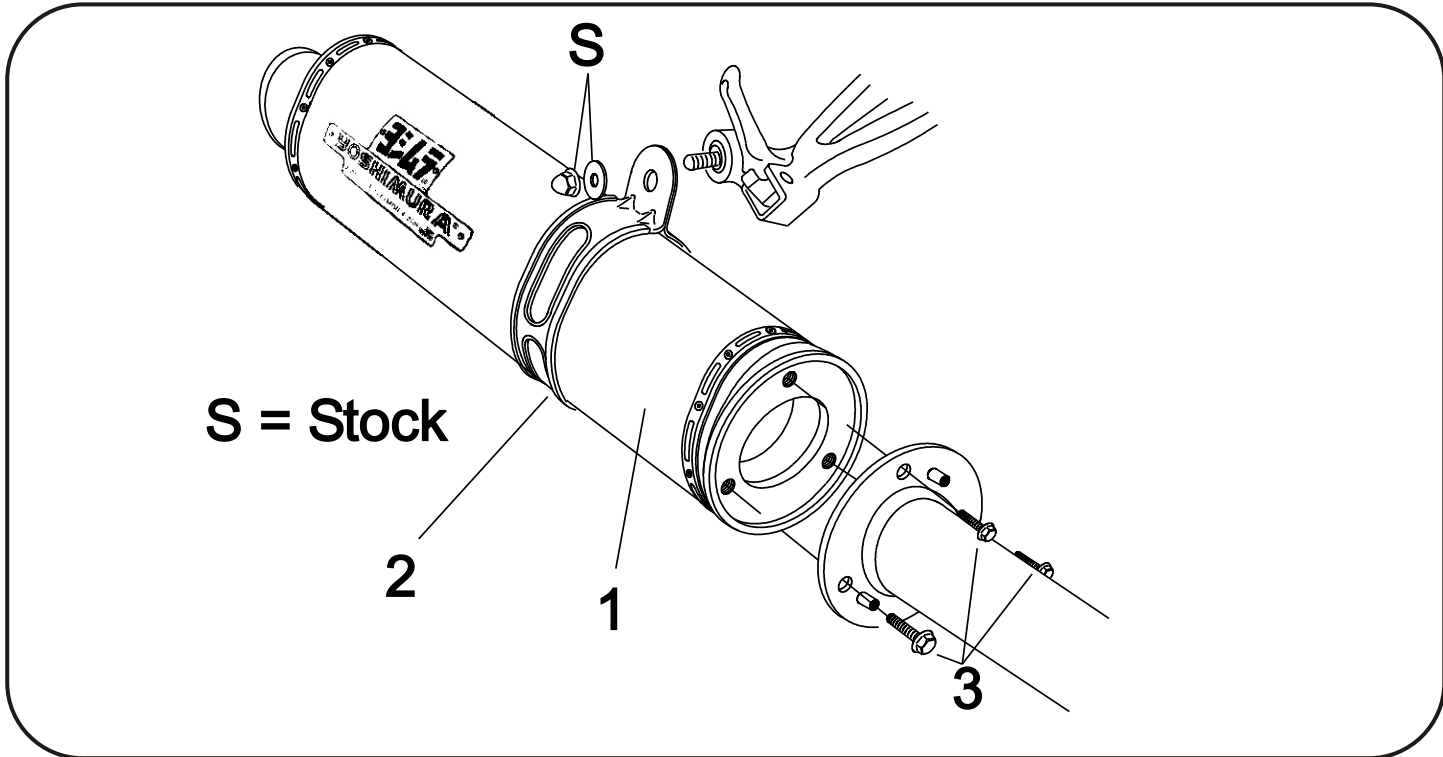

Fig. 3

#143045(2,5,7)/143055(2,5,7)



Parts Diagram

NO.	DESCRIPTION	QTY	PART #
1	RS-3 Bolt On Muffler Assembly	1	**
2	Stainless Steel Muffler Clamp Stainless Steel and Titanium Sleeve use Carbon Fiber Sleeve use	1	COS450S10ALX COS450S10AL
3	Flange Head Bolt	3	M8X20H
**	Muffler Clamp Heat Insulator	1	HT SHLDTRS
**	Yoshimura Vinyl Sticker	2	17028-BLK

Nuts and Bolts Guide (Actual Size):

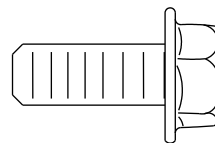

8mm x 20mm
Flange Hex Bolt