



# YOSHIMURA

RESEARCH & DEVELOPMENT OF AMERICA, INC.

5420 DANIELS STREET STE A, CHINO CA., 91710 · (800) 634-9166 · (909) 628-4722 · FAX (909) 591-2198

[www.yoshimura-rd.com](http://www.yoshimura-rd.com)

## Street Series

Qualified Manufacturer Declared "Replacement Part"

2009~2014

**Yamaha R1**

**1314202 (CF/CF)**

**1314205 (SS/CF)**

**R-77 Stainless Steel Slip-On**

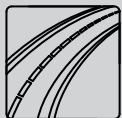

All Street Series systems are:

- Slip-on/Bolt-on applications that do not require tampering with the vehicle's emissions control system.
- CARB/EPA tail-pipe emissions compliant.
- Marked with appropriate EPA noise labels.
- Not tested for EPA new vehicle noise compliance.



*You must know how to remove and replace your stock exhaust in order to install this product otherwise have it installed by a professional mechanic. Keep all stock parts from your existing system as some components may be necessary to install your new Yoshimura exhaust depending on the application. Read through all instructions before beginning installation. Exhaust system can be extremely hot. Let motorcycle cool down before beginning installation. Always wear hand and eye protection and take precautionary measures to avoid injury.*



NOTE: IN THE STATE OF CALIFORNIA, IT IS ILLEGAL TO MODIFY THE EMISSION CONTROL SYSTEM, WHICH INCLUDES THE CARBURETORS OF ANY VEHICLE.

**Caution:** Exhaust system can be extremely hot. Let motorcycle cool down before beginning installation. Always wear hand and eye protection and take precautionary measures to avoid injury.

**Note:** Read through all instructions before beginning installation.

## Tools Needed:

10mm and 12mm Sockets	Torque Wrench
3/8" Ratchet and Extension	3/16" Drill Bit
3mm and 4mm Allen Wrench	Electric Drill
#2 Phillips Screwdriver	Safety Glasses

## Installation Steps:

1. Remove passenger seat.
2. Remove driver seat.
3. Remove upper portion of rear tail. (See Fig. 1 & 2)
  - Remove 2 front plastic screw type rivets. (Fig. 1)
  - Remove bolt. (Fig. 1)
  - Remove push type rivet. (Fig. 2)
  - Remove passenger seat lock cable.
  - Remove tailpiece.
4. Loosen tailpipe clamps. (Fig. 3)
5. Remove left and right muffler heatshields. (Fig. 4)
6. Remove left muffler mount bolt then remove muffler. Repeat for right muffler. (Fig. 5)

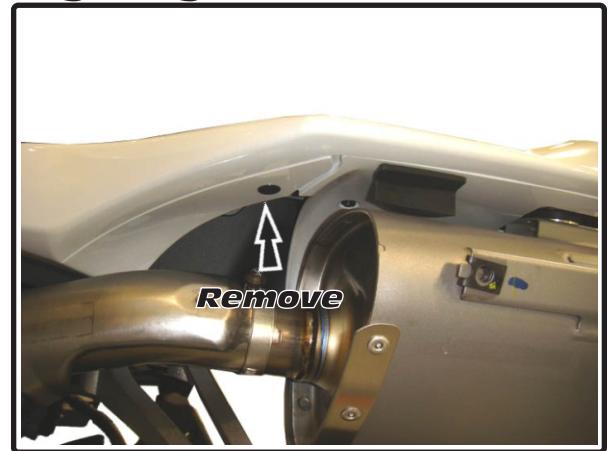

Fig. 2

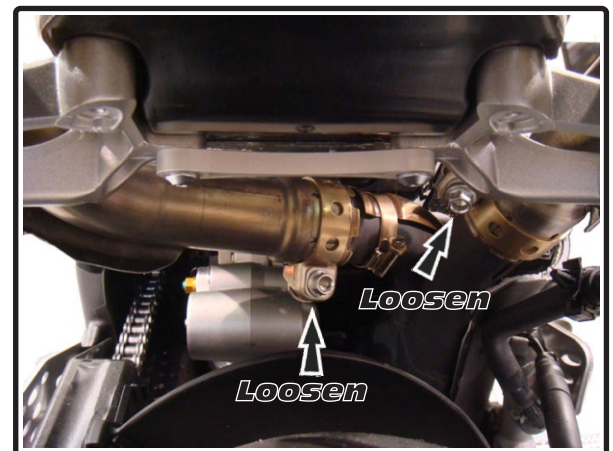

Fig. 3



Fig. 1



Fig. 4

7. Install Yoshimura collector clamp onto left Yoshimura tailpipe/muffler assembly.
8. Install left Yoshimura muffler assembly. Using stock bolt, tighten hand-tight. (Fig. 6)
9. Repeat steps for right Yoshimura muffler assembly.
10. Stand to the rear of the motorcycle and adjust mufflers and/or tailpipes to achieve desired fit, while checking all clearances.

**Note:** If insufficient clearances are found between bodywork and heatshields or tailpipes, loosen the midpipe clamp between the header and midpipe and adjust the orientation of the stock midpipe. Be sure to tighten the midpipe once orientation is set correctly.

11. Torque muffler mounting bolts to 16.5 lb-ft (2.3 kg-m)
12. Torque collector clamps to 16.5 lb-ft (2.3 kg-m)
13. Install left and right Yoshimura heatshields using supplied bolts. (Fig. 7)
14. Install tail fairing and seats using the reverse steps of removal.
15. It is recommended that the entire exhaust system be wiped down with rubbing alcohol to remove oil and fingerprints. This will help prevent tarnishing of the finish after the exhaust is heated up.
16. Before starting motorcycle, check for proper clearance between new exhaust system and motorcycle (i.e. Bodywork, swing-arm, etc.). If any problem is found, please carefully follow through the installation steps again. If problem still persists, please call Yoshimura tech. dept. at (800)634-9166 / in CA (909)628-4722

**NOTE:** After starting motorcycle, it is normal for new exhaust system and mufflers to emit smoke until oil residue burns off.

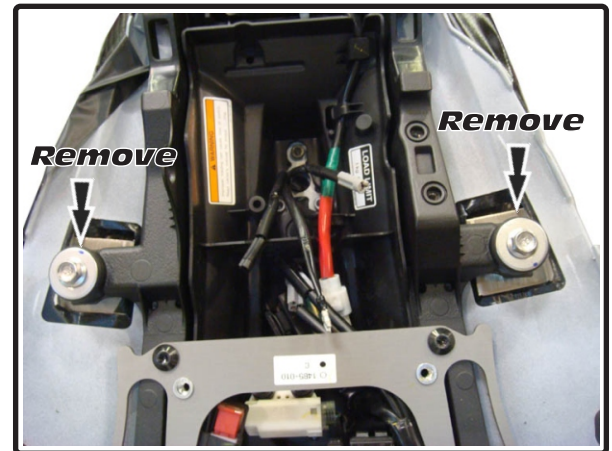
**Fig. 5****Fig. 6****Fig. 7**

**#131420(2,5,6,7)**

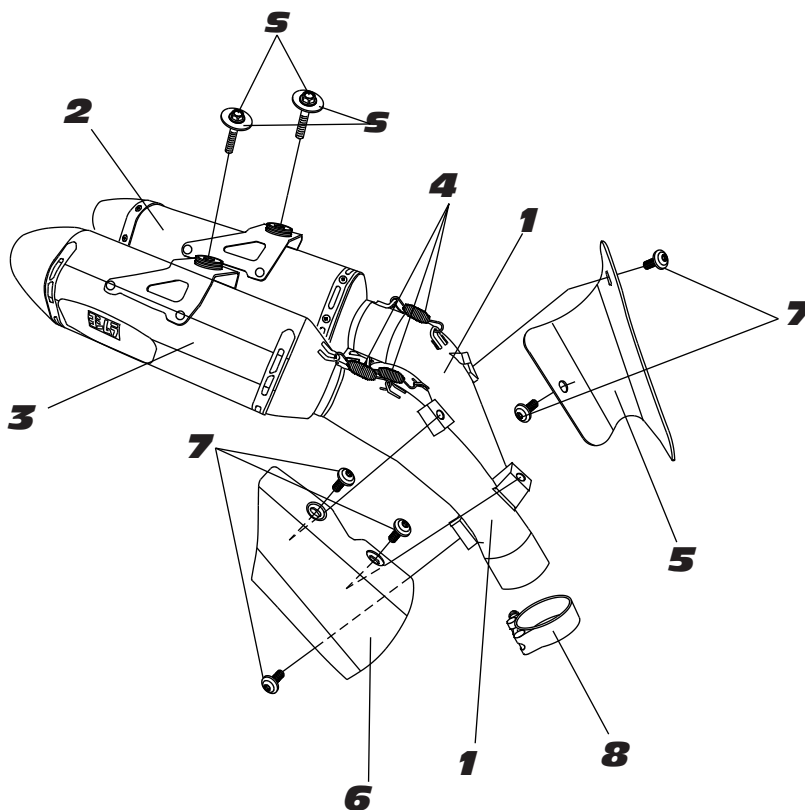

**S=STOCK**

Parts Diagram

NO.	DESCRIPTION	QTY	PART #
1	Yoshimura Tail Pipe		
	Stainless Steel (Left Side)	1	1314-426
	Stainless Steel (Right Side)	1	1314-427
2	Muffler (Left)	1	
	R77 Muffler with Carbon Fiber Sleeve		1314202-LMA
	R77 Muffler with Stainless Steel Sleeve		1314205-LMA
	R77 Muffler with Titanium Sleeve	1314207-LMA	
3	Muffler (Right)	1	
	R77 Muffler with Carbon Fiber Sleeve		1314202-RMA
	R77 Muffler with Stainless Steel Sleeve		1314205-RMA
	R77 Muffler with Titanium Sleeve	1314207-RMA	
4	Medium Exhaust Spring	4	RACE-SPS-1
5	Left Heatshield	1	1314-HSL
6	Right Heatshield	1	1314-HSR
7	Heatshield Bolts	5	RC116HSB-BK
8	Collector Clamp	2	22059
**	Low Volume Insert	2	INS-04-K
**	Low Volume Insert for SRR77126W-SS	2	INS-03-K
**	Exhaust Spring Puller	1	ST-200
**	Yoshimura Sticker Kit Sheet	1	17029