



YOSHIMURA

RESEARCH&DEVELOPMENT OF AMERICA, INC.

5420 DANIELS STREET STE A, CHINO CA., 91710 · (800) 634-9166 · (909) 628-4722 · FACSIMILE (909) 591-2198

www.yoshimura-rd.com

RACE SERIES

Qualified Manufacturer Declared "Modified Part"

Yamaha R1

131411M220 (CF/CF)

Alpha Titanium Full-System

FOR CLOSED COURSE COMPETITION ONLY; NOT INTENDED FOR STREET USE



Race Series systems are:

- NOT CARB/EPA tail-pipe emissions compliant.
- NOT street legal.
- For "Closed Course Competition" use only.



You must know how to remove and replace your stock exhaust in order to install this product otherwise have it installed by a professional mechanic. Keep all stock parts from your existing system as some components may be necessary to install your new Yoshimura exhaust depending on the application. Read through all instructions before beginning installation. Exhaust system can be extremely hot. Let motorcycle cool down before beginning installation. Always wear hand and eye protection and take precautionary measures to avoid injury.



NOTE: IN THE STATE OF CALIFORNIA, IT IS ILLEGAL TO MODIFY THE EMISSION CONTROL SYSTEM, WHICH INCLUDES THE CARBURETORS OF ANY VEHICLE.

Removal

1. Remove the heatshields on muffler and header.
2. Remove lower cowl and left / right fairing as per Factory Service Manual.
3. Remove the muffler exhaust clamp.
4. While securely supporting the stock muffler, remove the muffler mount bolt and carefully remove the stock muffler assembly.
5. Remove the two O2 sensors from the pre-muffler chamber assembly.
6. Disconnect and remove exhaust valve cables from the pre-muffler chamber assembly.

Note¹: Exhaust valve cables will not be used with the Yoshimura full-system. Remove exhaust valve cables from servo motor.

Note²: Do not disconnect servo motor connector.
7. Remove the three chassis mount bolts securing pre-muffler chamber assembly to frame.
8. While securely supporting the pre-muffler chamber assembly, loosen the two exhaust clamps between the header and carefully remove pre-muffler chamber assembly.
9. Remove the lower oil cooler bracket.
10. While securely supporting the header, remove header nuts and carefully remove the stock header.

Note: The stock exhaust port gaskets will be re-used with the Yoshimura full-system. Inspect and replace if necessary.

Installation

1. Remove the lower muffler mount bracket bolt from right footpeg bracket. Install (No. 9) *13141-RMBKT*, muffler bracket adapter on the backside of the muffler mount bracket using the provided (No. 10) *M8X16*, bolt.

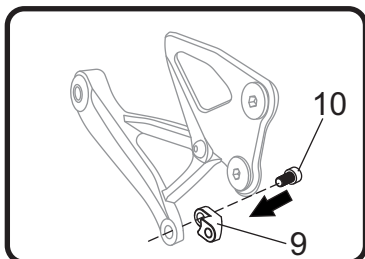

2. Align (No. 9) *13141-RMBKT*, muffler bracket adapter to the backside of the right footpeg bracket. Secure using the stock bolt.

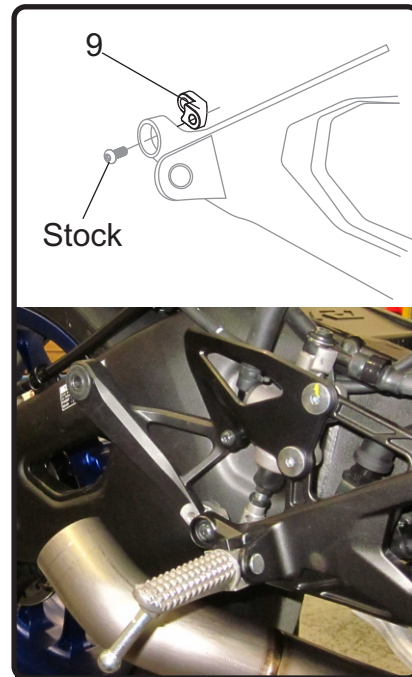

3. Install (No. 1) *13141SDM-00*, manifold and (No. 2) *13141SDR-00*, flange using the stock header nuts. Torque header nuts to factory specification. Hook (No. 7) *RACE-SPX-1-NL*, short spring without insulator onto the two lower holes on the flange.

Note: Exhaust port gaskets will be re-used.

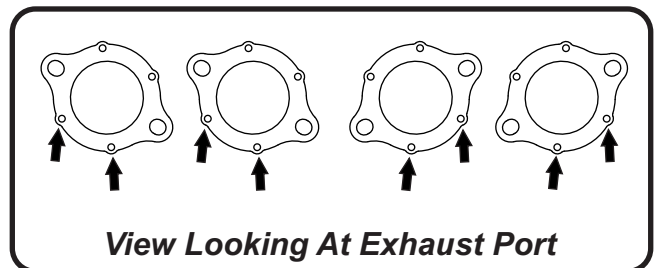

4. Slide header inlets over manifolds. Tap legs with a soft mallet to make sure header is completely seated. Hook exhaust springs hanging from flange onto header spring hooks.
5. Secure header chassis mount bracket to chassis using the stock chassis mount bolt, stock washer and provided (No. 13) *8MMNUT*, nut. See assembly diagram for proper orientation.
6. Install (No. 4) *13141-719*, tailpipe over header outlet and secure using (No. 7) *RACE-SPX-1-NL*, short spring without insulator.

7. Install (No. 5) *CRYM5127R*, muffler over tailpipe outlet. Slide (No. 6) *MCYM5-GCBY*, muffler clamp over muffler and secure to the backside of the stock muffler mount bracket using the provided (No. 11) *M8X45*, bolt, (No. 12) *M8ALCSW-00*, counter sink washer, (No. 14) *8MMWASHERL*, washer, and (No. 13) *8MMNUT*, nut. See diagram for proper orientation and order of hardware.
8. Install (No. 8) *RACE-SPS-1*, medium spring with insulator between the muffler and tailpipe.
9. Install the stock O2 sensors into (No. 3) *13141-704*, header.
10. Torque muffler mount bolt and chassis mount bolt to factory specification.
11. Re-install lower oil cooler bracket using the supplied *6X3SPCC*, aluminum spacer and stock bolt as shown below. Torque to factory specification.

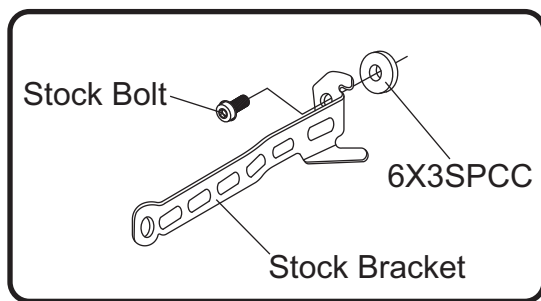

12. Before starting vehicle, check for proper clearance between new exhaust system and rear suspension (i.e. tire, swingarm, brakes, rear shock, and etc.) If any problem is found, please carefully follow through the installation steps again. If problem still persists, please call Yoshimura Tech Department at (800) 634-9166 / in CA (909) 628-4722.
13. It is recommended that the muffler and tailpipe be wiped down with rubbing alcohol to remove oil and fingerprints. This will help prevent tarnishing of the finish after the exhaust is heated up.