



YOSHIMURA

RESEARCH & DEVELOPMENT OF AMERICA, INC.

5420 DANIELS STREET STE A, CHINO CA., 91786 · (800)634-9166 · (909)628-4722 · FACSIMILE (909)591-2198

www.yoshimura-rd.com

RS-3/RS-1 PERFORMANCE EXHAUST

**SUZUKI
2001-05
GSF1200/S**

112525 (2,5,7)

STAINLESS STEEL RACE SLIP-ON SYSTEM

112535 (2,5,7)

STAINLESS STEEL ZYCLONE SLIP-ON SYSTEM

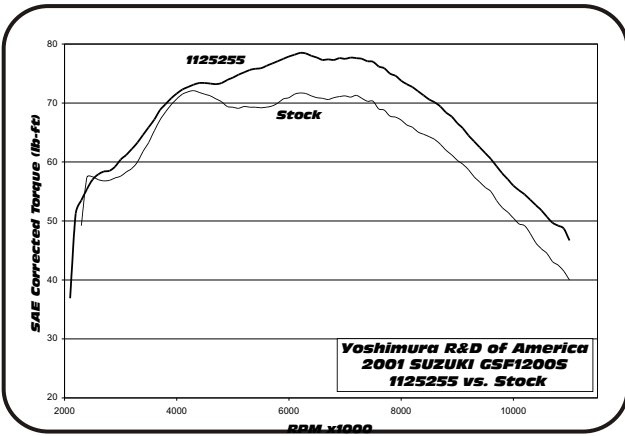
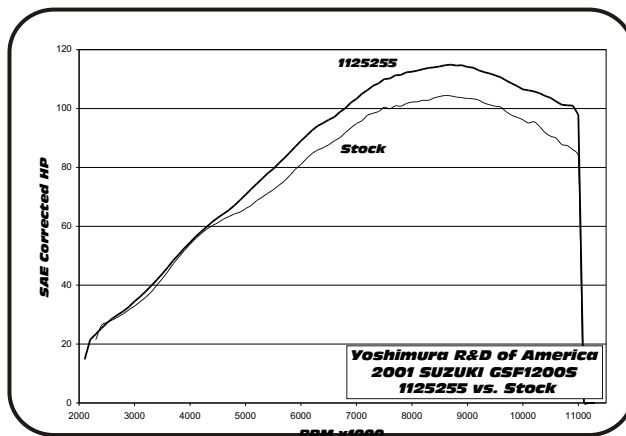

Note: Dyno graphs are for comparison use only. Actual results may vary depending on operating and motorcycle condition.



THIS PRODUCT IS DESIGNED FOR USE IN CLOSED COURSE RACING AND IS NOT INTENDED FOR HIGHWAY USE.



NOTE: IN THE STATE OF CALIFORNIA, IT IS ILLEGAL TO MODIFY THE EMISSION CONTROL SYSTEM, WHICH INCLUDES THE CARBURETORS OF ANY VEHICLE.

Caution: Exhaust system can be extremely hot. Let motorcycle cool down before beginning installation.

Note: Read through all instructions before beginning installation.

Tools Needed:

12mm socket
12mm wrench
Torque wrench

Installation Steps:

- 1 Remove stock tail-pipe with muffler. (See Fig.1&2)
- 2 Install new header collector exhaust gasket.
(Not supplied - Suzuki part no. 14771-27E00) NOTE: in some cases the collector gasket may stick to either the stock tailpipe or header - a gasket must be installed in the stock header.
- 3 Remove center stand stopper rubber grommet from stock tail-pipe and install on Yoshimura tail-pipe.
- 4 Install Yoshimura slip-on tail-pipe with muffler into stock header.
- 5 Install chassis mount bolt loosely. (See Fig.2)
- 6 Apply heat insulator to inside of muffler clamp then slide clamp onto muffler. (note direction of clamp in Fig. 3)
- 7 Mount muffler clamp to the outside of stock muffler bracket using stock bolt, washer, and nut. (See Fig. 3)
Torque bolt to 2.5 kg-m (18 lb-ft)
- 8 Torque chassis mount bolt to 2.5 kg-m (18 lb-ft)
- 9 Torque stock collector clamp bolt to 2.0 kg-m (14.5 lb-ft).
- 10 Before starting motorcycle, check for proper clearance between new muffler and motorcycle. (i.e. swing-arm, passenger foot-peg, rear wheel, etc.) If any problem is found, please carefully follow through the installation steps again. If problem still persists, please call Yoshimura technical department at (800)634-9166, in CA (909)628-4722

NOTE: After starting motorcycle, it is normal for new exhaust and muffler to emit smoke until oil residue burns off.

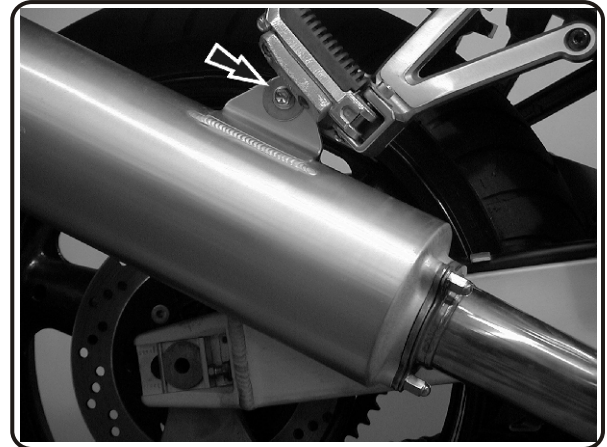
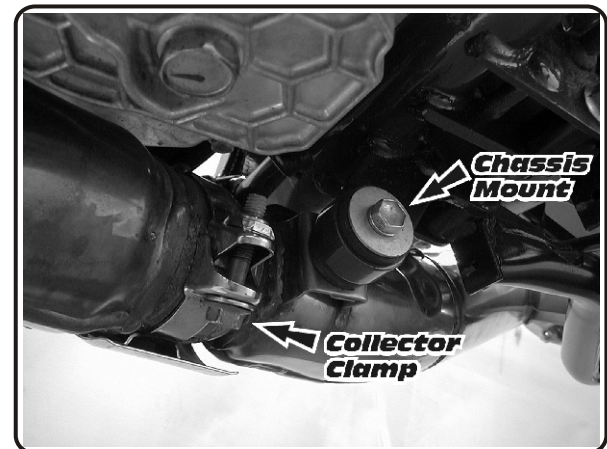
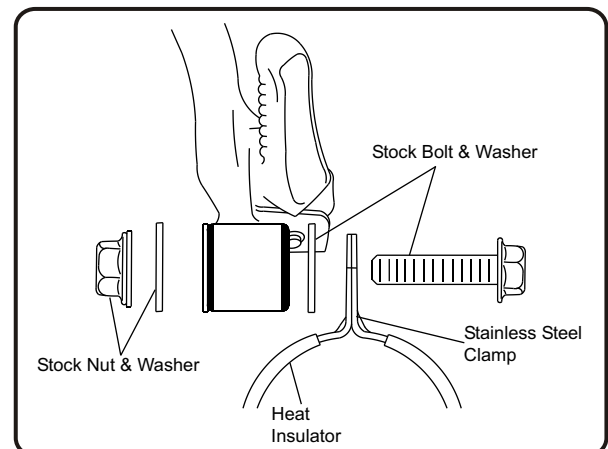
**Fig. 1****Fig. 2****Fig. 3**

#112525(2,5,7)/#112535 (2,5,7)

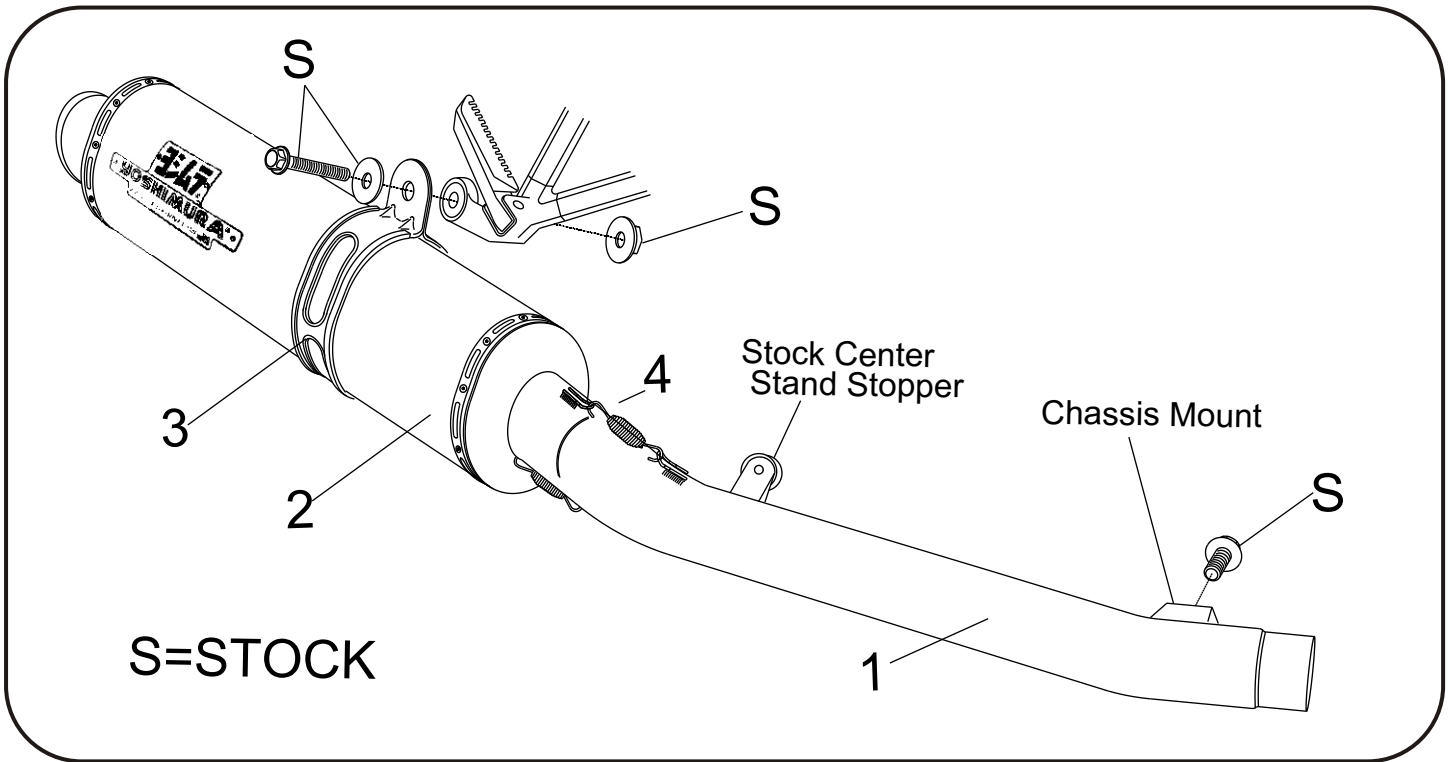

Parts Diagram

NO.	DESCRIPTION	QTY	PART #
1	Yoshimura Stainless Steel Tail-Pipe	1	1125-235-1
2	RS-1/RS-3 Muffer Assembly	1	**
3	Stainless Steel Muffer Clamp	1	
	Stainless Steel or Titanium Sleeve uses		COS450S8BLX
	Carbon Fiber Sleeve uses		COS450S8BL
4	Stainless Steel Spring	2	RACE-SPS-1
**	Muffer Clamp Heat Insulator	1	HT SHLDTRS
**	Yoshimura Vinyl Sticker	2	17028-BLK

NOTE:
For best performance with stock jetting, remove rubber snorkel from air box. (Located at the rear of airbox, in airbox filter lid)