



YOSHIMURA

RESEARCH&DEVELOPMENT OF AMERICA, INC.

5420 DANIELS STREET STE A, CHINO CA., 91710 · (800)634-9166 · (909)628-4722 · FACSIMILE (909)591-2198

www.yoshimura-rd.com

FENDER ELIMINATOR KIT

070BG131410
Yamaha R1

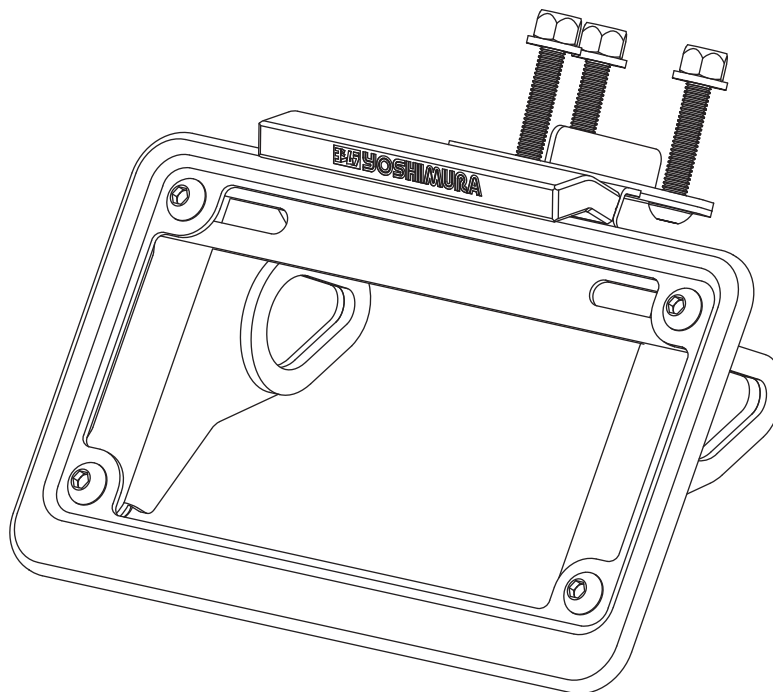

THIS PRODUCT IS NOT DOT APPROVED.

Yoshimura R&D of America, Inc. is not liable or responsible for any resulting event caused by the installation of this product. Check with local laws and regulations for compliance prior to installation and use. This product is not intended for use on public highways.



Assembly Diagram

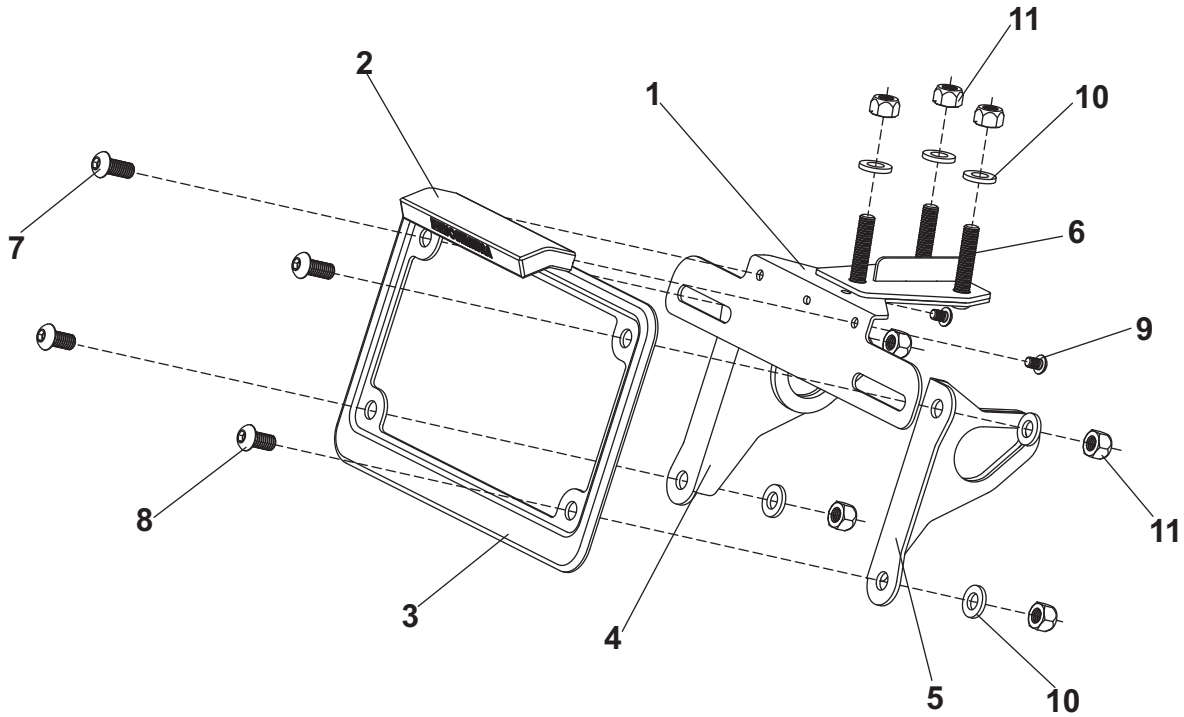

No.	Item	Description	Qty.
1	13141-FEBKT	Fender Eliminator Bracket	1
2	070BG-LH-K	LED License Plate Light	1
3	070BG-LPF	License Plate Frame	1
4	13630-TSBL-00	Left Turn Signal Bracket	1
5	13630-TSBR-00	Right Turn Signal Bracket	1
6	M6X30BHS	6mm x 30mm Button Head Screw	3
7	M6X16BHS	6mm x 16mm Button Head Screw	2
8	M6X14BHS	6mm x 14mm Button Head Screw	2
9	M4X6BHS	4mm x 6mm Button Head Screw	2
10	6MMWASHER	6mm Washer	7
11	6MMLN	6mm Nylon Lock Nut	7
**	94785-01-ND	Butt Connectors	2
**	ZT-400	Cable Ties	3
**	17029	Yoshimura Sticker Sheet	1
Optional Parts			
***	070BGUNVTBKT	Universal Turn Signal Bracket Kit	

*** The Yoshimura Universal Turn Signal Bracket Kit is to be used with aftermarket stud-mounted turn signals and is sold separately.

Removal

1. Remove passenger and rider seat.
2. Locate and disconnect license plate light and turn signal wires.
3. While securely supporting the stock fender assembly, remove the three bolts securing the fender assembly to subframe. Carefully remove the stock fender assembly making sure not damage the license plate light and turn signal connectors.

Note: The stock fender washer plate will not be used.

4. Remove left and right turn signals from the stock fender assembly.
5. Cut the stock license plate light connector from the stock fender assembly. Be sure to cut at least a 6" section of wire from the connector.

Installation

1. Install (No. 2) 070BG-LH-K, Yoshimura license plate light onto (No. 1) 13141-FEBKT, Yoshimura fender eliminator bracket using (No. 9) M4X6BHS, 4mm button head screws provided in the kit.

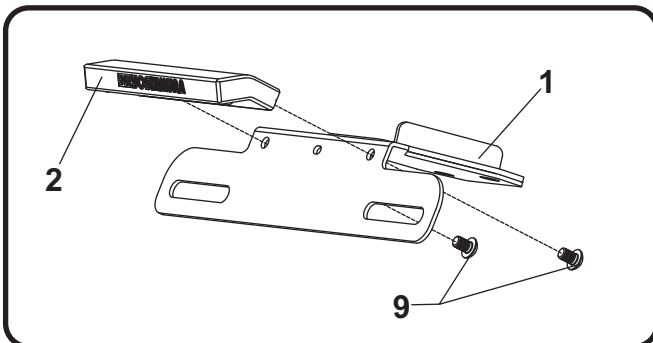

Note: Route license plate light wire through the hole under the fender eliminator bracket.

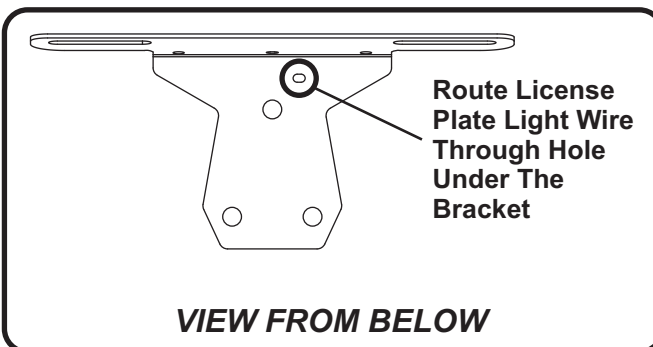

2. Install the stock left and right turn signals onto (No. 4,5) 13630-TSBL/R-00, turn signal brackets using the stock hardware.
3. Install (No. 4,5) 13630-TSBL/R-00, turn signal brackets and (No. 3) 070BG-LPF, license plate frame using the (No. 7,8) M6X14BHS and M6X12BHS, 6mm button head screws as shown in the assembly diagram.
4. Route license plate light and turn signal wires under passenger seat and secure assembled fender eliminator bracket to subframe using (No. 6) M6X30BHS, bolts, (No. 10) 6MMWASHER, washer and (No. 11) 6MMLN, nylon lock nuts.

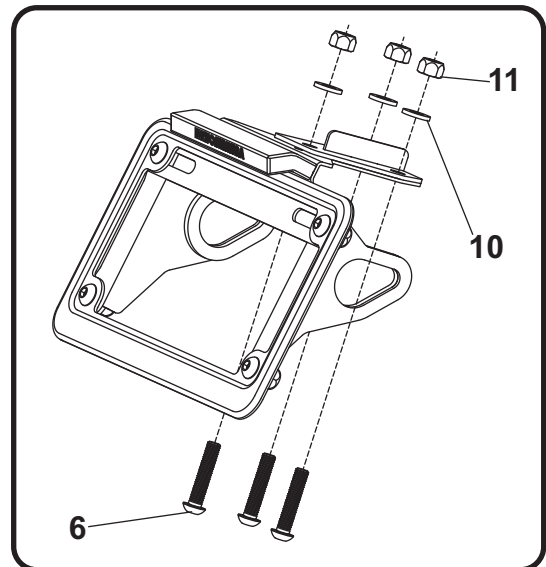

5. Using the 94785-01-ND, butt connectors provided in the kit, connect Yoshimura license plate light wires to the stock license plate light wires as follows:

Red -to- Blue w/ Red Stripe
Black -to- Black

6. Re-connect license plate light and turn signal connectors.
7. Re-install rider and passenger seat.
8. Check for proper function of license plate light, turn signals, brake light, and that all brackets and components are secure prior to riding.