

WOODCRAFT CFMOTORSPORTS

105 Baldwinville Rd
Winchendon, MA 01475
978-297-2977

05-0448 Yamaha R6 2006+ Rearset Instruction Sheet – Racing Use Only

Thank you for selecting CFMOTORSPORTS rearsets. The components you have just purchased for your motorcycle are designed to improve the ground clearance, crash worthiness and overall good looks of your motorcycle. Please note that these components are intended and approved for **racing use only**. As such, the footpegs are solid-mount and provisions for brake light switches and brake pedal return springs are generally not provided.

Remove stock rearsets, footpegs and associated hardware. The entire kickstand bracket assembly can be removed for race use. All components that are re-used in this kit should be cleaned and inspected for damage before re-installation.

IMPORTANT

Tighten all fasteners to factory specification or industry standard. FAILURE TO PROPERLY TIGHTEN ALL FASTENERS MAY CAUSE DAMAGE TO THE MOTORCYCLE, LOSS OF CONTROL AND SERIOUS INJURY OR DEATH

Brake Side Assembly Installation

- 1) Attach the CFM master cylinder bracket (2) and pipe bracket (3) to the right side rearset bracket using the included 6mm hardware. **IMPORTANT** -Secure the bolts with BLUE LOCTITE.
- 2) If you are using the CFM brake pedal, assemble the pivot (5), shaft (4) and tip (9) with the included bolts. **IMPORTANT** - Secure all bolts with BLUE LOCTITE.
- 3) Bolt the CFM footpeg (6) and the brake pedal (OEM or CFM) to the bracket using the included 10mm hardware. Be sure to generously apply quality waterproof grease to the sliding surface of the footpeg to ensure smooth lever operation. **IMPORTANT** - Secure the bolt with BLUE LOCTITE
- 4) Optional - The OEM heel guard may be attached to the back side of the bracket. The rear mount will use the supplied spacer (13) and bolt (14). **IMPORTANT** -Secure the bolts with BLUE LOCTITE.
- 5) Bolt the bracket to the frame and attach the master cylinder to the bracket using the OEM hardware. Re-connect the brake pedal to the master cylinder clevice using the OEM pin and clip.
- 6) If you are using the OEM brake pedal the stock lever return spring may be attached to the lever and secured using the hook tab on the bottom of the bracket.
- 7) Adjust the brake pedal to the desired height using the OEM adjustment threads at the base of the master cylinder.

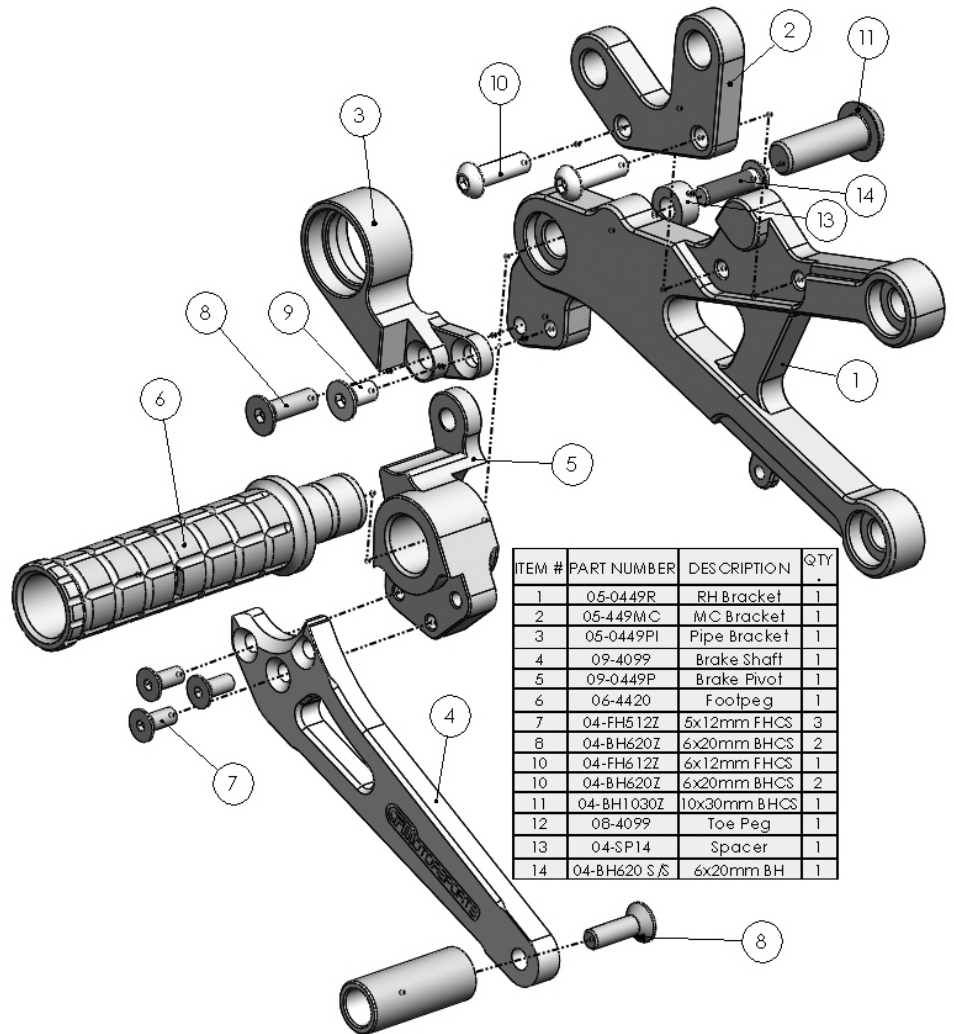

ITEM #	PART NUMBER	DESCRIPTION	QTY
1	05-0449R	RH Bracket	1
2	05-449MC	MC Bracket	1
3	05-0449PI	Pipe Bracket	1
4	09-4099	Brake Shaft	1
5	09-0449P	Brake Pivot	1
6	06-4420	Footpeg	1
7	04-FH512Z	5x12mm FHCS	3
8	04-BH620Z	6x20mm BHCS	2
10	04-FH612Z	6x12mm FHCS	1
10	04-BH620Z	6x20mm BHCS	2
11	04-BH1030Z	10x30mm BHCS	1
12	08-4099	Toe Peg	1
13	04-SP14	Spacer	1
14	04-BH620 S/S	6x20mm BH	1

Shift Side Assembly Installation

Standard Shift Pattern

- 1) Remove the gear change actuator (the part connected to the motor) and flip it so that the bend in the arm is oriented to the outside of the motorcycle. Remove the OEM hiem joint (8) and re-attach it so that it sits on the outside of the actuator. **IMPORTANT** - Secure bolt with BLUE LOCTITE.
- 2) Assemble the shift pivot (12), shaft (3) and tip (4) with the included bolts. **IMPORTANT** -Secure all bolts with BLUE LOCTITE. Attach the hiem joint (13) to the top of the pedal arm.
- 3) Bolt the CFM footpeg (2) to the bracket (1) using the included 10mm hardware. **IMPORTANT** - Secure bolt with BLUE LOCTITE. Bolt the CFM left bracket to the frame using the OEM hardware.
- 4) Attach the shift rod (16) simultaneously to the shift pedal and gear change actuator. The rod and actuator should be oriented so that they are approximately 90 degrees to each other. Rotate the rod until the desired pedal height is achieved. The rod should lie outside the frame. Lock the rod in place with the 6mm nuts.
- 5) Bolt the shift pedal to the bracket using the OEM hardware. Note that the OEM shim (10) and wave washer (11) are used as shown. Be sure to generously apply quality waterproof grease to the sliding surface of the footpeg to ensure smooth lever operation. **IMPORTANT** – Secure bolt (5) with BLUE LOCTITE

ITEM NO.	PART NUMBER	DESCRIPTION	QTY
1	05-0449L	LH Bracket	1
2	06-4300	Footpeg	1
3	08-1449	Shift Shaft	1
4	08-4099	Toe Peg	1
5	OEM Bolt	---	---
6	04-FH620D	6x20mm FHCS	1
7	04-BH1030Z	10x30mm BHCS	1
8	OEM Hiem	---	1
9	OEM Wave Wash	---	1
10	OEM Shim	---	1
11	04-BH625Z	6x25mm BHCS	1
12	08-0448P	Shift Pivot	1
13	08-6MLH	6mm MRH Hiem	1
14	04-LN6	6mm Lock Nut	1
15	07-21025	Shift Rod	1
16	04-FN6LZ	6mm LH Nut	2
17	04-FH516FZ	5x1 6mm FHCS	3
18	OEM RH Nut	---	1

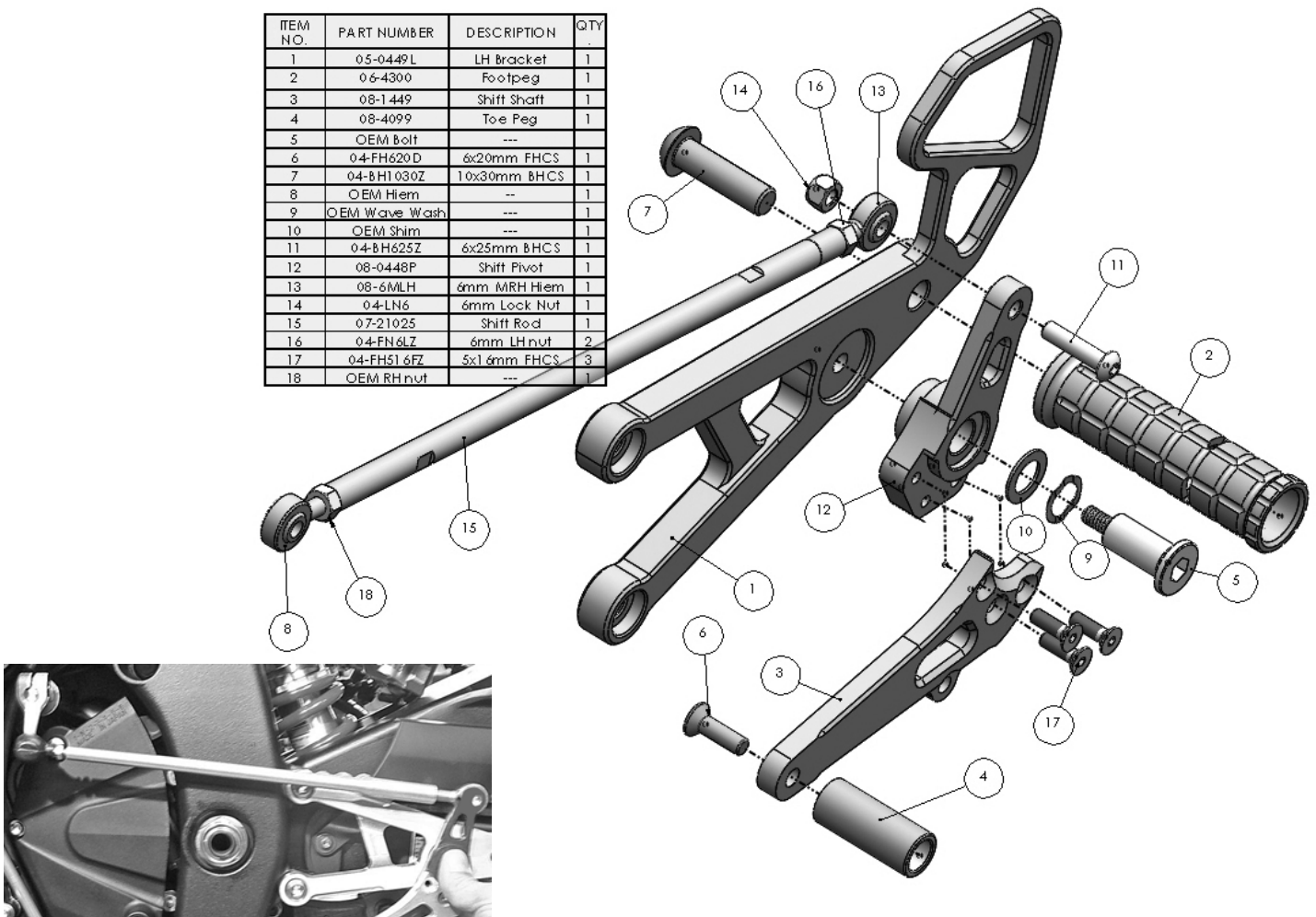

BE SURE THAT ALL COMPONENTS OPERATE AND RETURN FREELY BEFORE USE
 If you have any questions regarding installation, please feel free to contact us.

IMPORTANT

Installation and use of this product will change the response of the motorcycle to rider control inputs. Failure of the rider to adapt to these changes may result in a loss of control, and serious injury or death. Improper installation and/or failure to comply with all warnings and instructions may cause a loss of control and serious injury or death. **DO NOT INSTALL OR USE THIS PRODUCT IF YOU ARE UNABLE TO DO SO IN COMPLIANCE WITH ALL INSTRUCTIONS AND WARNINGS. SEEK THE ASSISTANCE OF A TRAINED PROFESSIONAL TECHNICIAN.**