



Installation Instructions

60-0454RB Cover Protector

1) Attach the skid plate to the Woodcraft cover by bolting it from the inside.

IMPORTANT – USE BLUE THREADLOCKING COMPOUND ON THE THREE SKID PLATE MOUNTING BOLTS. Coat the threads completely and allow the threadlocking compound to fully set before use.

2) The 60-2500 rubber pad should be adhered to the back side of the cover in the pocket.

3) Install the Woodcraft cover using the included mounting hardware in the 4 locations shown above. Torque for these mounting bolts is about 7 ft-lbs.

Note: The lower bolt is different from the other three. Be sure to use the proper bolt in each hole.

4) Start the motorcycle and inspect for any leaks before riding.

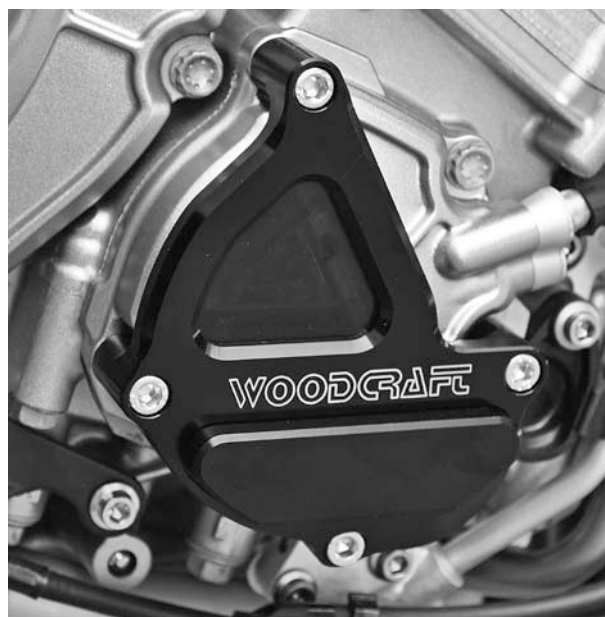
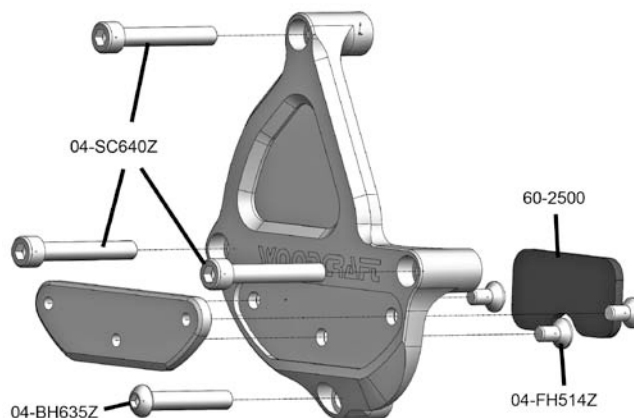

WARNING

Installation of Woodcraft Billet Covers involves removal and reinstallation of certain factory components such as fasteners, alternator stators and oil-retention gaskets. **FAILURE TO INSTALL THESE COMPONENTS IN COMPLIANCE WITH ALL SPECIFIC INSTRUCTIONS SUPPLIED WITH BILLET COVER KIT, MAY CAUSE OIL LOSS OR DAMAGE TO ENGINE RESULTING IN LOSS OF CONTROL OF MOTORCYCLE AND SERIOUS INJURY OR DEATH.**