



Installation Instructions

60-0247LO Start Idle Gear Cover Instructions

1) Remove the OEM idle gear cover from the motor. You should be able to remove the cover without removing the start idle gear. If the pin supporting the gear pulls out of the case, be sure to carefully note the order of the idle gear and any washers in the assembly. We have included a photo of the assembly from the OEM microfiche at the right.

2) Clean and inspect all OEM parts before re-installation.

3) Completely clean the gasket surface. Install the cover using the OEM O-ring (remove from the OEM cover). A light coat of grease will ease installation of the cover. Tighten all bolts to OEM specifications (normally 8 ft lbs).

4) Start the motorcycle and inspect for any leaks before riding.

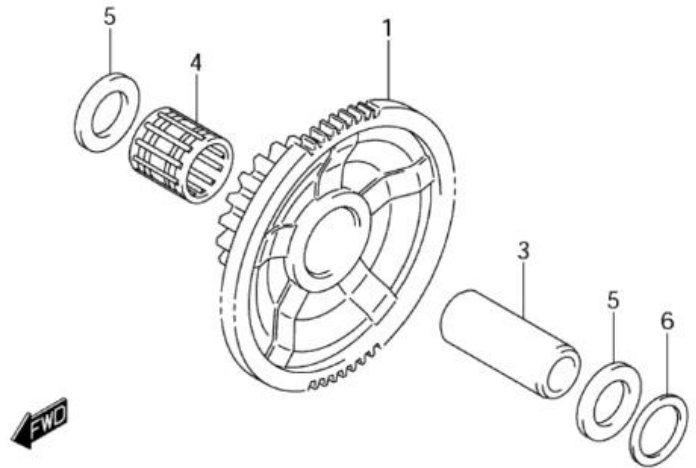

WARNING

Installation of Woodcraft Billet Covers involve removal and reinstallation of certain factory components such as fasteners, alternator stators and oil-retention gaskets. **FAILURE TO INSTALL THESE COMPONENTS IN COMPLIANCE WITH ALL SPECIFIC INSTRUCTIONS SUPPLIED WITH BILLET COVER KIT, MAY CAUSE OIL LOSS OR DAMAGE TO ENGINE RESULTING IN LOSS OF CONTROL OF MOTORCYCLE AND SERIOUS INJURY OR DEATH.**