

# WOODCRAFT CFMOTORSPORTS

105 Baldwinville Rd  
Winchendon, MA 01475  
(978)297-2977

[www.woodcraft-cfm.com](http://www.woodcraft-cfm.com)

## 05-0168/0169 Kawasaki Ninja ZX10 2011-15 Rearset Instruction Sheet

Thank you for selecting CFMOTORSPORTS rearsets. Please note that these components are intended and approved for **racing use only**. As such, the footpegs are solid-mount and provisions for brake light switches are not provided with the kit.

- 1) Remove stock rearsets, footpegs and associated hardware. All components that are re-used in this kit should be cleaned and inspected for damage before re-installation.

### **IMPORTANT**

Tighten all fasteners to factory specification or industry standard. FAILURE TO PROPERLY TIGHTEN ALL FASTENERS MAY CAUSE DAMAGE TO THE MOTORCYCLE, LOSS OF CONTROL AND SERIOUS INJURY OR DEATH

### Brake Side Assembly Installation

- 1) Attach the CFM brake pin to the back of the bracket. Assemble the CFM brake pedal. **IMPORTANT** - Secure all bolts with LOCTITE. Attach the brake pedal to the pin using the stock bolt & washer, placing the spacer from the OEM rearsets between the pedal and the bracket. Be sure to apply quality waterproof grease to the the pin.
- 2) Bolt the CFM footpeg loosely to the bracket using supplied 10mm bolt.
- 3) Bolt the brake bracket assembly loosely to the frame using the supplied 8mm bolts. Experiment with different mounting locations for the bracket and footpeg until you find what is most comfortable.
- 4) Tighten the footpeg bolt. **IMPORTANT** - Secure the footpeg bolt with LOCTITE.
- 5) Bolt the master cylinder to the bracket using the supplied bolts. The bolts first go through the heel guard, then through the main bracket. There are spacers that need to be placed between the master cylinder and the back side of the bracket - **the thicker spacer is used in the upper hole**. Tighten the main bolts thread into the master cylinder the top bolt should stick through the back side.
- 6) Attach the fluid reservoir bracket to the back side of the top master cylinder bolt using the included 8mm locknut. There is not a lot of room, so the locknut will need to be tightened with a wrench by hand. Orient the reservoir as shown and secure with the supplied nut and bolt.
- 7) Attach the master cylinder to the brake pedal using the stock hardware and adjust the stock brake pedal to your desired height.

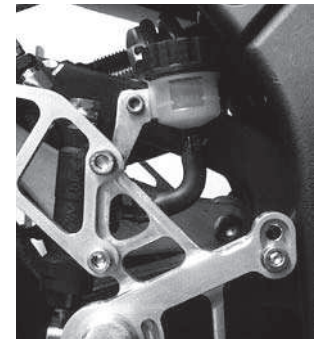
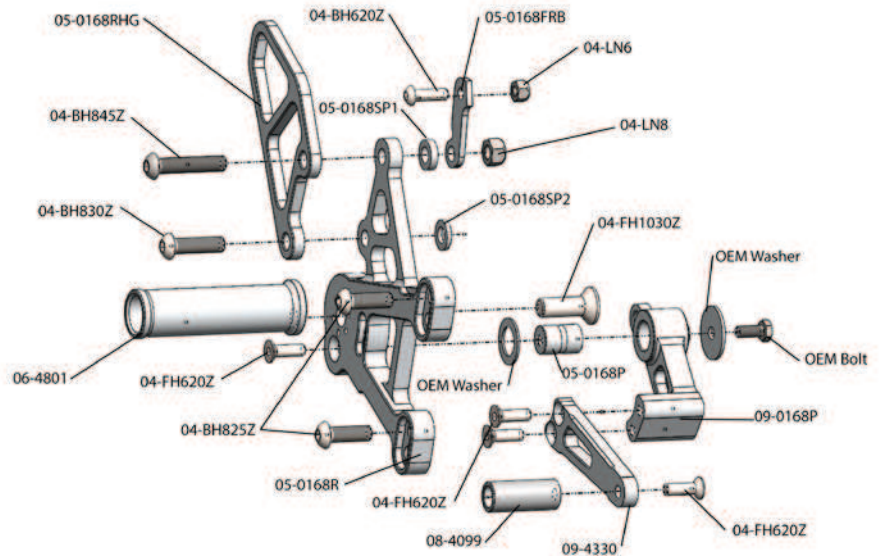

### Shift Side Assembly Installation

- 1) Bolt the CFM footpeg to the bracket using the included 10mm hardware. Be sure to use the same location as you did on the brake side. **IMPORTANT** - Secure the bolt (#11) with LOCTITE.
- 2) Assemble the CFM shift pedal. **IMPORTANT** - Secure bolts (#10) with LOCTITE. Attach the hiem joint to the back side of the pedal using bolt #12 and secure it with the 6mm lock nut.

### We suggest using the UPPER hole in the shift pivot for a stock lever feel

- 3) Attach the shift lever to the bracket using bolt #14 and Pivot Pin #5. Be sure to generously apply quality waterproof grease to the sliding surface of the bolt to ensure smooth lever operation. **IMPORTANT** - Secure bolt with LOCTITE.
- 4) Bolt the main bracket to the same location as the brake side using #9 bolts.

### Standard Shift

- 5) Take the nut off the OEM shift pedal and thread it on the hiem joint on the CFM pedal. Connect the OEM shift rod to the CFM shift pedal and stock shift spline by threading it on both parts simultaneously.
- 6) Be sure that the shift rod makes a 90 degree angle with the stock shift spline. Adjust the pedal to the desired height, lock the rod in place with nuts on both sides of the rod.

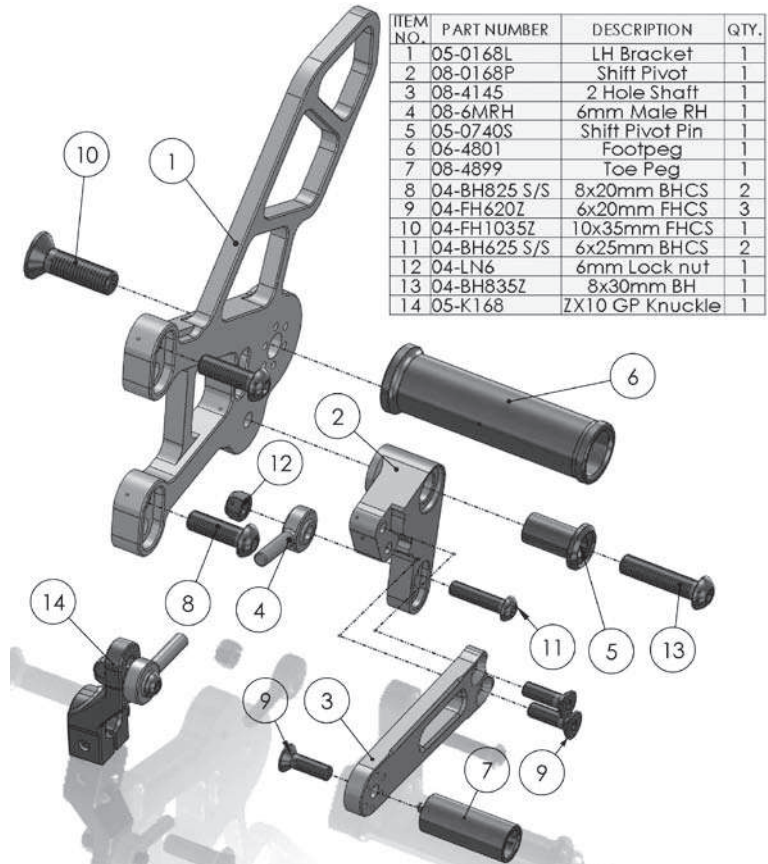

### GP Shift

- 7) Take the nut off the OEM shift pedal and thread it on the hiem joint on the CFM pedal.
- 8) Remove the OEM shift knuckle and replace it with the ZX10 GP shift knuckle (#15). Orient the arm pointing straight up.
- 9) Connect the OEM shift rod to the CFM shift pedal and ZX10 GP knuckle by threading it on both parts simultaneously. Be sure that the shift rod makes a 90 degree angle with the stock shift spline. When the pedal is at the desired height, lock the rod in place with nuts on both sides of the rod.

If after testing you want shifts that require less pressure and slightly longer lever travel, move the hiem joint on the #14 knuckle to the top hole. If you want shorter throw shifts that take slightly more force, move the hiem joint to the bottom hole on the #2 shift pivot (note this will make finding neutral more difficult)

### **BE SURE THAT ALL COMPONENTS OPERATE AND RETURN FREELY BEFORE USE**

If you have any questions regarding installation, please feel free to contact us.

### **IMPORTANT**

Installation and use of this product will change the response of the motorcycle to rider control inputs. Failure of the rider to adapt to these changes may result in a loss of control, and serious injury or death. Improper installation and/or failure to comply with all warnings and instructions may cause a loss of control and serious injury or death. **DO NOT INSTALL OR USE THIS PRODUCT IF YOU ARE UNABLE TO DO SO IN COMPLIANCE WITH ALL INSTRUCTIONS AND WARNINGS. SEEK THE ASSISTANCE OF A TRAINED PROFESSIONAL TECHNICIAN.** Installation of this product releases the Woodcraft Technologies, Inc. from all liabilities as to the use of this product. The user recognizes that any alteration or modification to any motorcycle may increase the risk of injury or accident and may also render the motorcycle illegal for public road use