



Kawasaki ZX10 08-10 RH Starter Cover 60-0165RIB Installation Instructions

1) Remove the outer start idle gear cover and all components. Be sure to be careful to note the orientation of the gears, shafts, pins and any washers. These parts will be installed exactly the same fashion in the Woodcraft cover.

2) Remove the starter cover and be sure to again carefully note the orientation of the gears, shafts, pins and any washers. Remove the locating dowel pins from the stock cover and slide them into the Woodcraft cover before installation.

3) Completely clean the gasket surface and be sure to inspect all stock components before re-assembly.

4) Install the skid plate in the Woodcraft cover. It is helpful to put a very small dab of oil on the o-ring to ensure that it does not twist during installation. **Important: the mounting bolts for the skid pad must be completely coated with Blue Loctite before installation. Be sure to read the instructions and allow the Loctite to cure before riding.**

5) Install the Woodcraft starter cover, using extra care to place the OEM gear assembly back in place correctly. The cover should be installed with a new gasket and all bolts torqued to OEM specifications. It is often helpful to put a little grease on the starter to aid in sliding the cover over the end.

6) Install the OEM start idle gear assembly and secure the start idle gear cover (either Woodcraft or OEM will work) with a new gasket.

7) Start the motorcycle, run for several minutes and inspect the cover carefully for any leaks before riding.

Skid Plate Replacement

In the case that you should ever need to replace the skid plate, you will need to melt the loctite used during installation. This is done by heating the skid plate gently with a propane torch for about 30 seconds. Always replace the o-rings whenever you replace the skid plate.

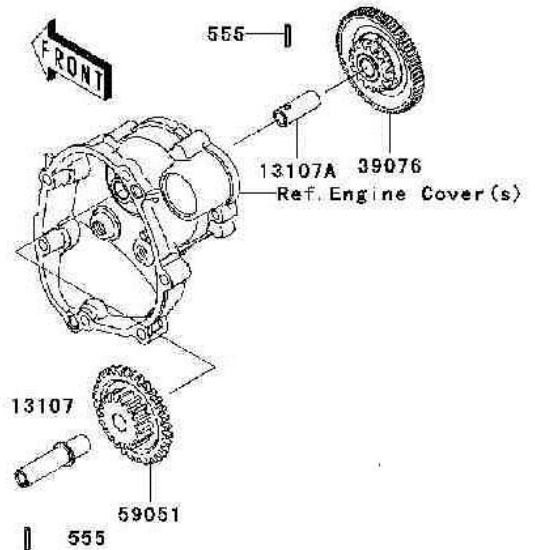

WARNING

Installation of Woodcraft Billet Covers involve removal and reinstallation of certain factory components such as fasteners, alternator stators and oil-retention gaskets. FAILURE TO INSTALL THESE COMPONENTS IN COMPLIANCE WITH ALL SPECIFIC INSTRUCTIONS SUPPLIED WITH BILLET COVER KIT, MAY CAUSE OIL LOSS OR DAMAGE TO ENGINE RESULTING IN LOSS OF CONTROL OF MOTORCYCLE AND SERIOUS INJURY OR DEATH.