

WOODCRAFT CFMOTORSPORTS

105 Baldwinville Rd
Winchendon, MA 01475
978-297-2977

05-0457B Yamaha R6 2017/2006+ GP Rearset Instruction Sheet – Racing Use Only

Thank you for selecting CFMOTORSPORTS rearsets. The components you have just purchased for your motorcycle are designed to improve the ground clearance, crash worthiness and overall good looks of your motorcycle. Please note that these components are intended and approved for **racing use only**. As such, the footpegs are solid-mount and provisions for brake light switches and brake pedal return springs are generally not provided.

Remove stock rearsets, footpegs and associated hardware. The entire kickstand bracket assembly can be removed for race use. All components that are re-used in this kit should be cleaned and inspected for damage before re-installation.

IMPORTANT

Tighten all fasteners to factory specification or industry standard. FAILURE TO PROPERLY TIGHTEN ALL FASTENERS MAY CAUSE DAMAGE TO THE MOTORCYCLE, LOSS OF CONTROL AND SERIOUS INJURY OR DEATH

Brake Side Assembly Installation

- 1) Assemble the CFM brake pedal. Bolt the pivot (09-0456P), shaft (09-4145) and tip (08-4899) together with the included bolts. Leave the pedal tip finger tight at this point as you will likely adjust the position after fitting the footpeg.
IMPORTANT - Secure all bolts in this step with BLUE LOCTITE.
- 2) Bolt the CFM footpeg (06-4801) bracket using the included 04-FH1035Z hardware. After testing the various positions and making your final selection - **IMPORTANT** - Secure the bolt with BLUE LOCTITE.
- 3) Bolt the brake pedal to the back side of the bracket using the 04-FH620Z bolt, 04-WA719 washer and 05-0225P pin. Be sure to apply a generous amount of waterproof grease on the surface of the pin.
IMPORTANT - Secure the bolt with BLUE LOCTITE.
- 4) Attach the master cylinder to the bracket using the 04-BH820Z hardware. Connect the brake pedal to the master cylinder clevice using the OEM pin and clip.
- 5) Adjust the brake pedal to the desired height using a combination of the adjustable tip the OEM adjustment threads at the base of the master cylinder. After selecting your final position, tighten this bolt and - **IMPORTANT** - Secure the bolts with BLUE LOCTITE.
- 6) Secure the RH Bracket to the frame using the OEM hardware.
- 7) Replace the lower subframe bolt with the 04-SC1050Z Bolt, 05-0456MCB reservoir bracket and 05-0445MSP10 spacer. The reservoir is bolted to the 05-0456MCB bracket with the stock bolt and supplied 04-LN5Z lock nut. Adjust the angle of the hose coming off the OEM master cylinder to allow the reservoir to connect to the bracket.

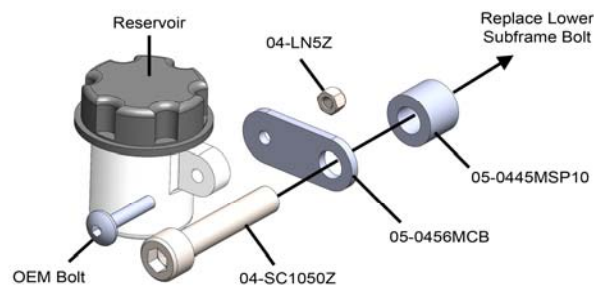
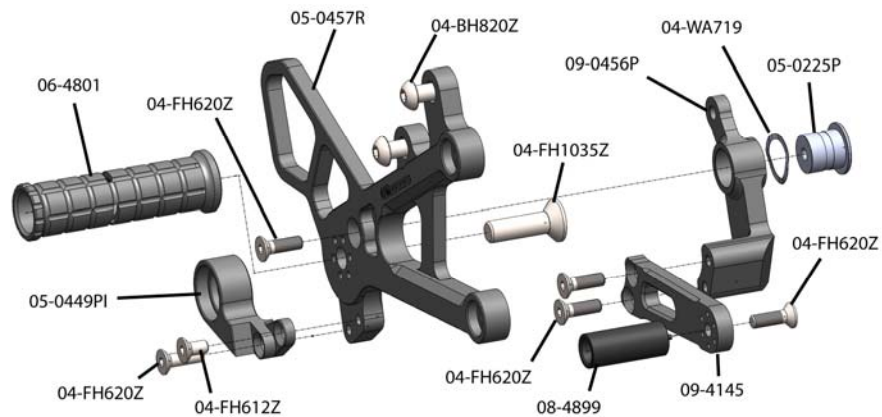

Shift Side Assembly Installation

GP Shift Pattern

- 1) Remove the gear change actuator (the part connected to the motor) and flip it so that the bend in the arm is oriented to the outside of the motorcycle. Remove the OEM hiem joint and attach the Woodcraft hiem 08-6FRH so that it sits on the outside of the actuator. The actuator must be rotated so that it is 90 degrees to the shift rod (see photo below). This corresponds to having the arm approximately in the 7 o'clock position. **IMPORTANT** - Secure the bolt with **BLUE LOCTITE**.
- 2) Assemble the shift pivot (08-0449P), shaft (08-4456) and tip (08-4899) with the included bolts. **IMPORTANT** -Secure all bolts with **BLUE LOCTITE**.
- 3) Attach the hiem joint (08-6FLH) to the pedal arm (08-4456) with the bolt, nut and spacer as shown below.
- 4) Bolt the CFM footpeg (06-4801) to the bracket (05-0457L) using the included 10mm hardware. Be sure to use the same eccentric position as you did on the right side. **IMPORTANT** - Secure bolt with **BLUE LOCTITE**.
- 5) Bolt the CFM left bracket to the frame using the OEM hardware.
- 6) Bolt the shift pedal to the bracket using the OEM hardware. Note that the OEM shim and wave washer are used as shown. Be sure to generously apply quality waterproof grease to the sliding surface of the footpeg to ensure smooth lever operation. **IMPORTANT** – Secure the OEM bolt with **BLUE LOCTITE**
- 7) Attach the shift rod (07-10625) simultaneously to the shift pedal and gear change actuator. The rod and actuator should be oriented so that they are approximately 90 degrees to each other. Rotate the rod until the desired pedal height is achieved. The rod should lie outside the frame. Lock the rod in place with the 6mm nuts.

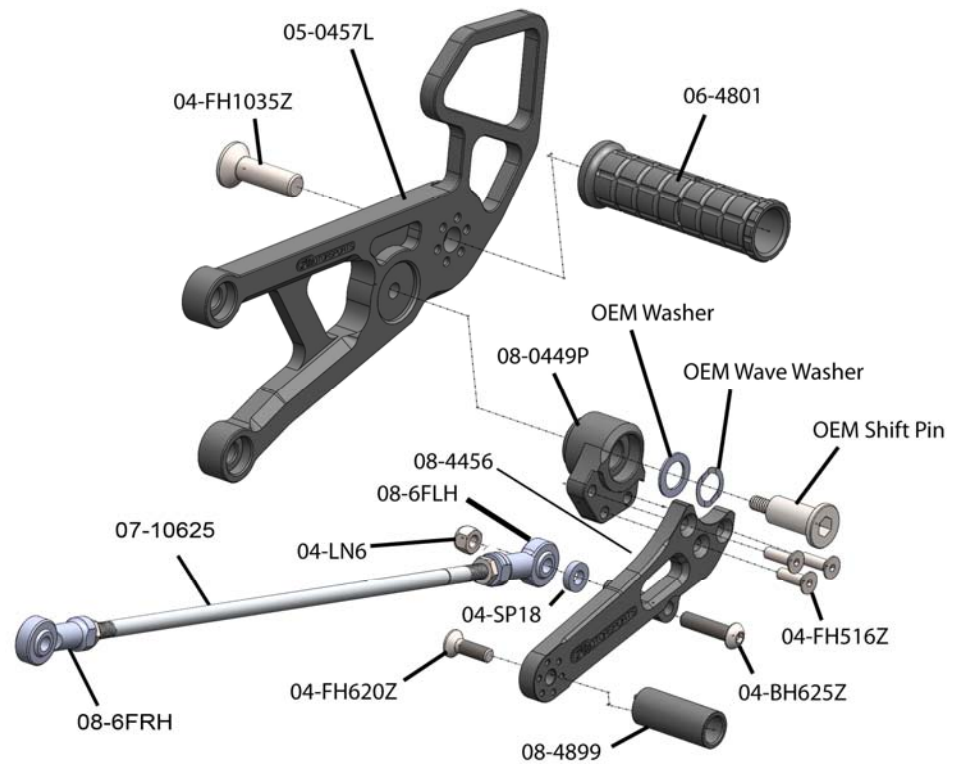

BE SURE THAT ALL COMPONENTS OPERATE AND RETURN FREELY BEFORE USE

If you have any questions regarding installation, please feel free to contact us.

IMPORTANT

Installation and use of this product will change the response of the motorcycle to rider control inputs. Failure of the rider to adapt to these changes may result in a loss of control, and serious injury or death. Improper installation and/or failure to comply with all warnings and instructions may cause a loss of control and serious injury or death. **DO NOT INSTALL OR USE THIS PRODUCT IF YOU ARE UNABLE TO DO SO IN COMPLIANCE WITH ALL INSTRUCTIONS AND WARNINGS. SEEK THE ASSISTANCE OF A TRAINED PROFESSIONAL TECHNICIAN.**