

WOODCRAFT CFMOTORSPORTS

105 Baldwinville Rd
Winchendon, MA 01475
(978)297-2977

www.woodcraft-cfm.com

05-0416 Yamaha FZ10 Rearset Instruction Sheet – Racing Use Only

Thank you for selecting CFMOTORSPORTS rearsets. Please note that these components are intended and approved for **racing use only**. As such, the footpegs are solid-mount and there are no brake light switches or return springs included.

- 1) Remove stock rearsets, footpegs and associated hardware. All components that are re-used in this kit should be cleaned and inspected for damage before re-installation.

IMPORTANT

Tighten all fasteners to factory specification or industry standard. **FAILURE TO PROPERLY TIGHTEN ALL FASTENERS MAY CAUSE DAMAGE TO THE MOTORCYCLE, LOSS OF CONTROL AND SERIOUS INJURY OR DEATH**

Shift Side Assembly Installation

- 1) Bolt the CFM footpeg to the main 05-0416L bracket using the included 10mm hardware. Once you have chosen your final position - **IMPORTANT** - secure bolt with LOCTITE.
- 2) Bolt the main 05-0416L bracket to the frame using the OEM hardware.
- 3) Assemble the CFM shift pedal 09-4145, 08-0416P, 08-7099E, 08-4099. **IMPORTANT** - Secure the bolts with LOCTITE.
- 4) Attach the pedal to the main bracket with the combination of included and OEM hardware shown below. **IMPORTANT** - Secure the main 04-BH840Z bolt with LOCTITE. Be sure to apply quality waterproof grease to the surface of the 05-0416P pin.
- 5) Bring the pedal to the desired height using a combination of the OEM shift rod and the eccentric toe piece. **IMPORTANT** - Secure these bolts with LOCTITE.
- 6) Attach the OEM heim joint to the outside of the shift pedal. **IMPORTANT** - Secure this bolt with LOCTITE.

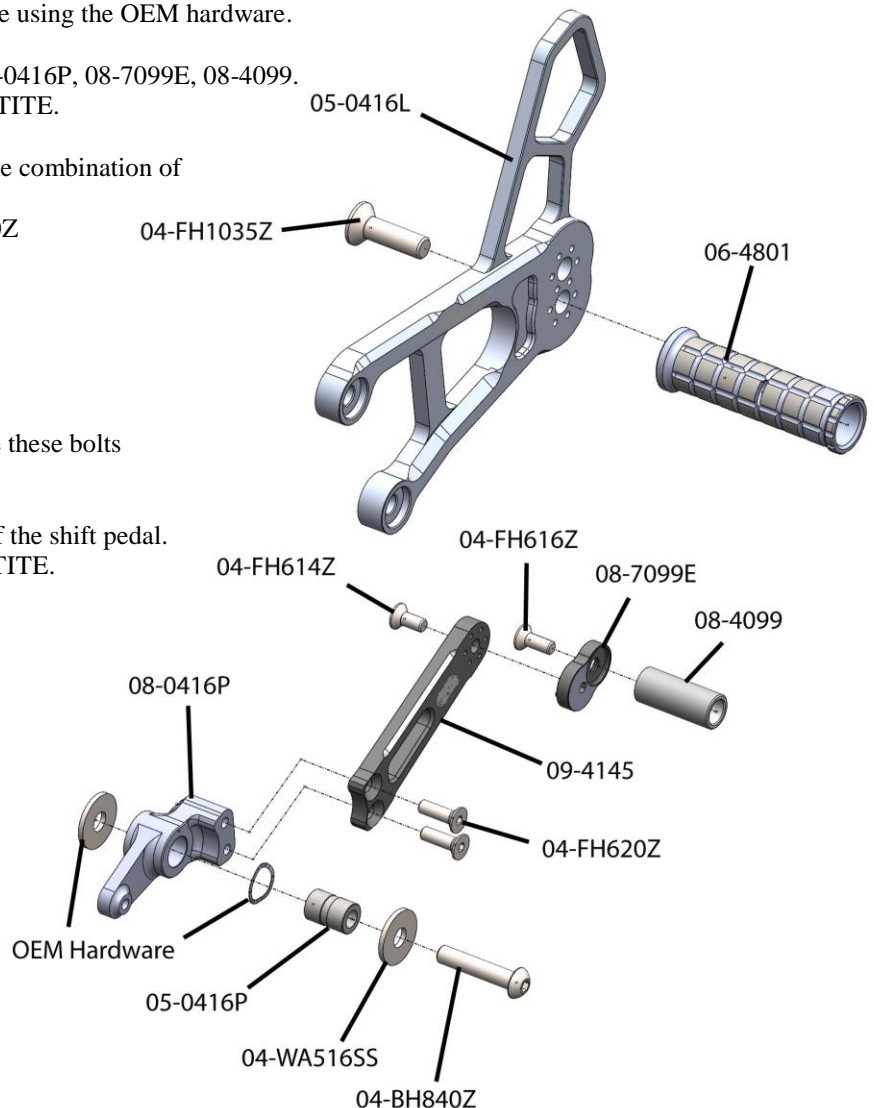

Brake Side Assembly Installation

IMPORTANT - Secure all bolts in this assembly with BLUE LOCTITE

1) Bolt the CFM footpeg to the 05-0416R main bracket using the included 10mm hardware.

2) Assemble the CFM brake pedal: 09-4145, 09-0416P, 08-4899 with included bolts. Be sure to apply quality waterproof grease to the surface of the 09-0416P brake pivot.

3) Attach the brake pedal to the back of the main bracket using the OEM bolt and all of the stock washers.

4) Bolt the OEM pipe mount bracket to the main bracket 05-0416R using the bolts shown in the diagram.

5) Find the 5 x 20mm button head bolt and nut in your kit. Coat the threads with Loctite and screw the bolt into the pedal. When it bottoms, lock the nut against the back of the pedal using the 04-FN5RZ nut.

6) Install the 04-SC510Z bolt in the 5mm blind hole on the back side of the bracket. Install the OEM brake light switch bracket using the 04-SC610Z bolt and hook the spring to the 04-BH520Z bolt from step 5.

7) Bolt the main bracket assembly to the frame using the OEM hardware.

8) Bolt the heel guard to the bracket using the 04-BH830Z bolts. These bolts pass (in order) through the heel guard, then the main 05-0416R bracket and finally thread into the OEM master cylinder. The master cylinder can then be connected to the brake pedal using the OEM hardware.

9) Adjust the height of the brake pedal using the eccentric tip of the pedal and the adjuster at the base of the master cylinder.

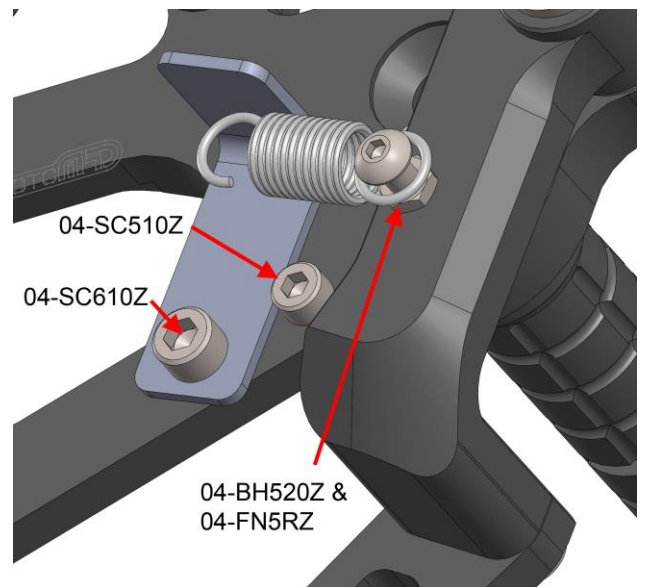
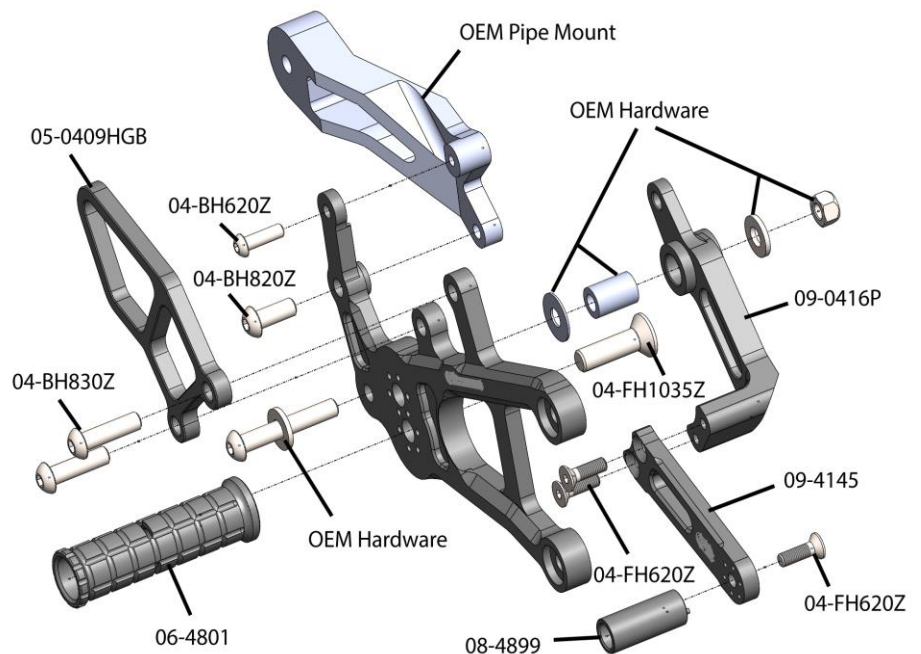

BE SURE THAT ALL COMPONENTS OPERATE AND RETURN FREELY BEFORE USE If you have any questions regarding installation, please feel free to contact us.

IMPORTANT

Installation and use of this product will change the response of the motorcycle to rider control inputs. Failure of the rider to adapt to these changes may result in a loss of control, and serious injury or death. Improper installation and/or failure to comply with all warnings and instructions may cause a loss of control and serious injury or death. **DO NOT INSTALL OR USE THIS PRODUCT IF YOU ARE UNABLE TO DO SO IN COMPLIANCE WITH ALL INSTRUCTIONS AND WARNINGS. SEEK THE ASSISTANCE OF A TRAINED PROFESSIONAL TECHNICIAN.** Installation of this product releases the Woodcraft Technologies, Inc. from all liabilities as to the use of this product. The user recognizes that any alteration or modification to any motorcycle may increase the risk of injury or accident and may also render the motorcycle illegal for public road use