



YOSHIMURA

RESEARCH&DEVELOPMENT OF AMERICA, INC.

5420 DANIELS STREET STE A, CHINO CA 91710 · (800)634-9166 · (909)628-4722 · FACSIMILE (909)591-2198

WWW.YOSHIMURA-RD.COM

Street Series

Kawasaki Z800

148002M220 (CF/CF)

148002M520 (SS/CF)

Alpha Stainless Steel Slip-On

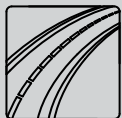

All Street Series systems are:

- Slip-on/Bolt-on applications that do not require tampering with the vehicle's emissions control system.
- CARB/EPA tail-pipe emissions compliant.
- Marked with appropriate EPA noise labels.
- Not tested for EPA new vehicle noise compliance.



You must know how to remove and replace your stock exhaust in order to install this product otherwise have it installed by a professional mechanic. Keep all stock parts from your existing system as some components may be necessary to install your new Yoshimura exhaust depending on the application. Read through all instructions before beginning installation. Exhaust system can be extremely hot. Let motorcycle cool down before beginning installation. Always wear hand and eye protection and take precautionary measures to avoid injury.



NOTE: IN THE STATE OF CALIFORNIA, IT IS ILLEGAL TO MODIFY THE EMISSION CONTROL SYSTEM, WHICH INCLUDES THE CARBURETORS OF ANY VEHICLE.

Assembly Diagram

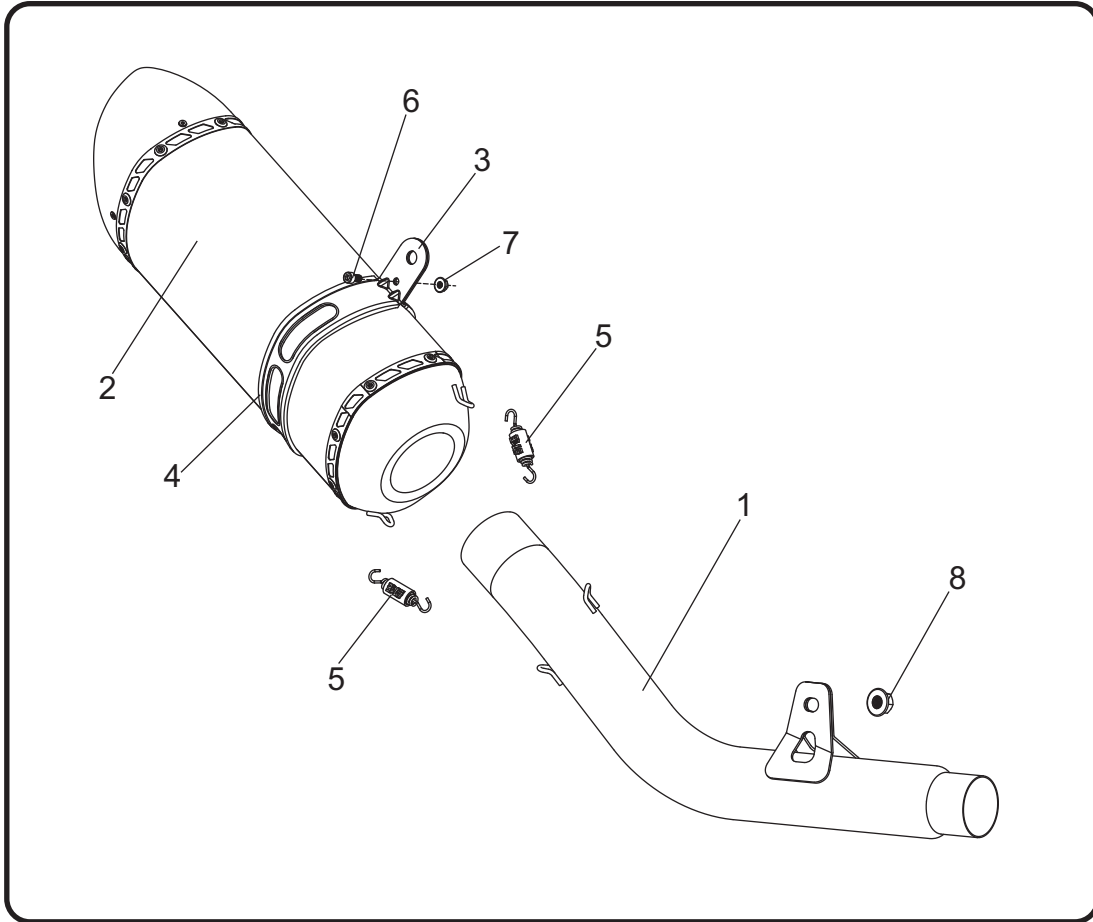

No.	Item	Description	Qty.
1	14800-435	Yoshimura Tailpipe	1
2	CRYM5126RA SRYM5126RA	Carbon Fiber Muffler Assembly Stainless Steel Muffler Assembly	1
3	MCYM5-DFCX MCYM5-DFCX-X	Muffler Clamp for use with CF sleeve for use with SS sleeve	1
4	HT SHLDR77	Muffler Clamp Heat Insulator	1
5	RACE-SPS-1	Medium Exhaust Spring	2
6	M5X10 BOLT	5mm x 10mm Socket Head Cap Bolt	1
7	5MMFNUT	5mm Flange Nut	1
8	10MMFNUT	10mm Flange Nut	1
**	INS-20-K	Low Volume Insert	1
**	ST-200	Spring Puller Tool	1
**	17029	Sticker Sheet	1

** Not shown on diagram.

CAUTION: Exhaust system can be extremely hot. Let motorcycle cool down before beginning installation. Always wear hand and eye protection and take precautionary measures to avoid injury.

WARNING: Always properly support vehicle with a stand and/or lift when servicing or performing any work. Unstable vehicles may present dangerous conditions and may cause property damage and/or personal injury.

NOTE: Read through all instructions before beginning installation.

Removal

1. Remove the three exhaust heatshield bolts and carefully remove the heatshield.
2. Using a short arm or modified allen wrench, remove the exhaust valve cover on the stock muffler to access exhaust valve cables.
3. Loosen exhaust valve cable nuts and remove exhaust valve cables from the stock muffler assembly.
4. Loosen the stock exhaust clamp between header and muffler.
5. Remove the muffler chassis mount bolt.
6. While securely supporting the stock muffler, remove the muffler mount bolt and carefully remove the stock muffler assembly.

Note: The stock exhaust gasket will be re-used. Inspect and replace if necessary.
7. Remove the passenger and rider seat.
8. Follow steps in Service/Owners Manual to remove right side covers to access the servo motor.
9. Remove the retaining clip securing exhaust valve cables to the servo motor and carefully remove the exhaust valve cables from pulley.

Note¹: Exhaust valve cables will not be used with the Yoshimura Slip-On system.

Note²: Do not disconnect servo motor connector as it may potentially cause malfunction indicators to appear on the display.

10. Re-install the right side covers using the reverse steps of removal.
11. Re-install rider and passenger seat.

Installation

1. Install (No. 4) *HT SHLDR77*, muffler clamp heat insulator onto (No. 3) *MCYM5-DFCX(-X)*, muffler clamp.
2. Install (No. 1) *14800-435*, tailpipe inlet into the stock header outlet.
3. Align chassis mount bracket to the front side of chassis and secure using the stock chassis mount bolt, washer, and supplied (No. 8) *10MMFNUT*, nut.
4. Install (No. 2) *muffler* onto (No. 1) *14800-435*, tailpipe.

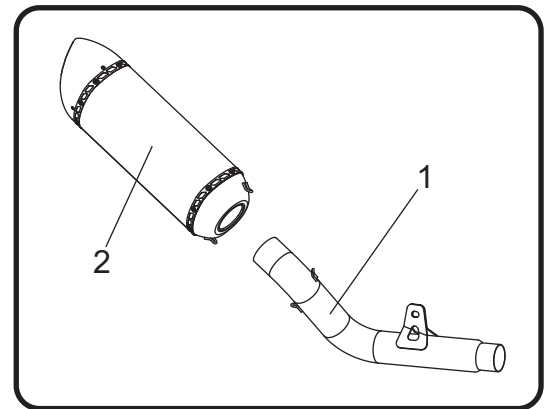

5. Slide (No. 3) *MCYM5-DFCX(-X)*, muffler clamp over (No. 2) *muffler* and align to the stock muffler mount. Secure using the stock muffler mount bolt and nut. Torque to factory specification.

Note: Muffler clamp mounts to the frontside of the muffler mount.

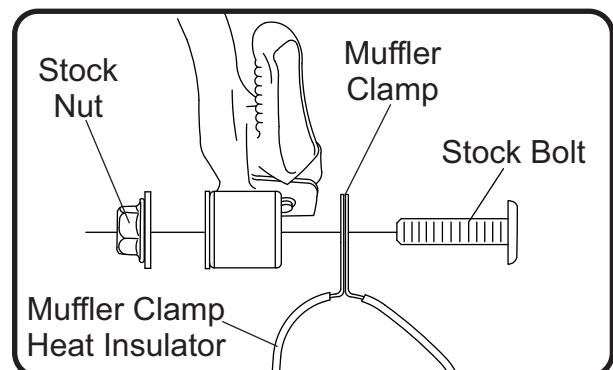

6. Install (No. 6,7) *M5X10 BOLT* and *5MMFNUT*, bolt and nut onto the lower hole in muffler clamp.
7. Install (No. 5) *RACE-SPS-1*, medium exhaust springs between muffler and tailpipe.
8. Torque tailpipe chassis mount bolt to factory specification.
9. Torque the stock exhaust clamp on header to factory specification.
10. Before starting vehicle, check for proper clearance between new exhaust system and rear suspension (i.e. tire, swingarm, brakes, rear shock, and etc.) If any problem is found, please carefully follow through the installation steps again. If problem still persists, please call Yoshimura Tech Department at (800) 634-9166 / in CA (909) 628-4722.
11. It is recommended that the muffler and tailpipe be wiped down with rubbing alcohol to remove oil and fingerprints. This will help prevent tarnishing of the finish after the exhaust is heated up.

Note: After starting motorcycle, it is normal for new exhaust system and muffler to emit smoke until oil residue burns off.